

LED Controller for LLC converters

Features

- Advanced LED Controller IC for high efficiency low-cost LLC converters with bipolar transistors and integrated PFC
- PSR - +/-5% Primary Side Regulation of LED current and voltage with no Flicker
- 50% duty cycle, variable frequency control of resonant half-bridge
- Automatic dead-time control and capacitive mode protection
- Protection modes:
 - Overload
 - No-Load
 - Internal Over-temperature
 - External Over-temperature (NTC)
- Low output capacitance allows live LED connection
- Very low output current ripple < 2%
- Small SO8 IC package



SO8

Applications

- Single stage PFC LED drivers without flicker
- CC LED drivers up to 100W

Order code

Part Number	Package	Packaging
RED2511AD-TR13	SO8	Tape and reel

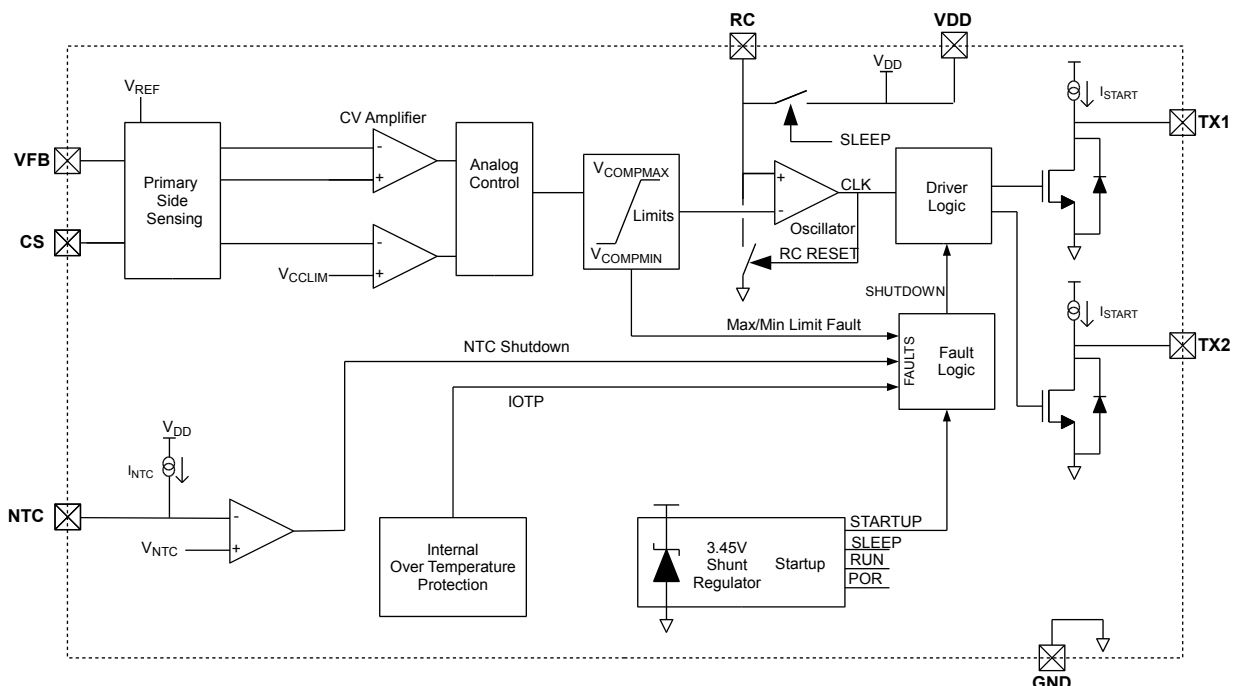

Figure 1: Block diagram

Device Pins

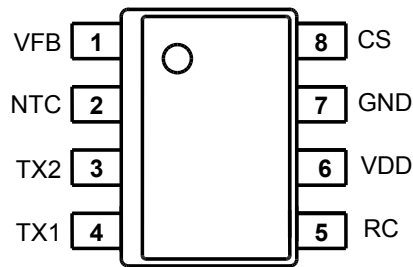

Figure 2: SO8 pin connections (top view)

Pin Functions

Pin #	Name	Function
1	VFB	PSR Feedback input for output voltage regulation. Connect to primary sense winding.
2	NTC	Shutdown pin that can be used for over-temperature protection with an external NTC resistor. A voltage of $<V_{NTC}$ will shut the IC down. Pin also includes a current source.
3	TX2	Output to control transformer.
4	TX1	Output to control transformer.
5	RC	External RC network sets the minimum [full power] switching frequency.
6	VDD	IC Power Supply pin – nominally 3.45V
7	GND	Chip ground.
8	CS	PSR Current Sense input provides output current regulation and cycle-by-cycle over-current protection. The CS pin is connected to the half-bridge current sense resistor

Typical Application

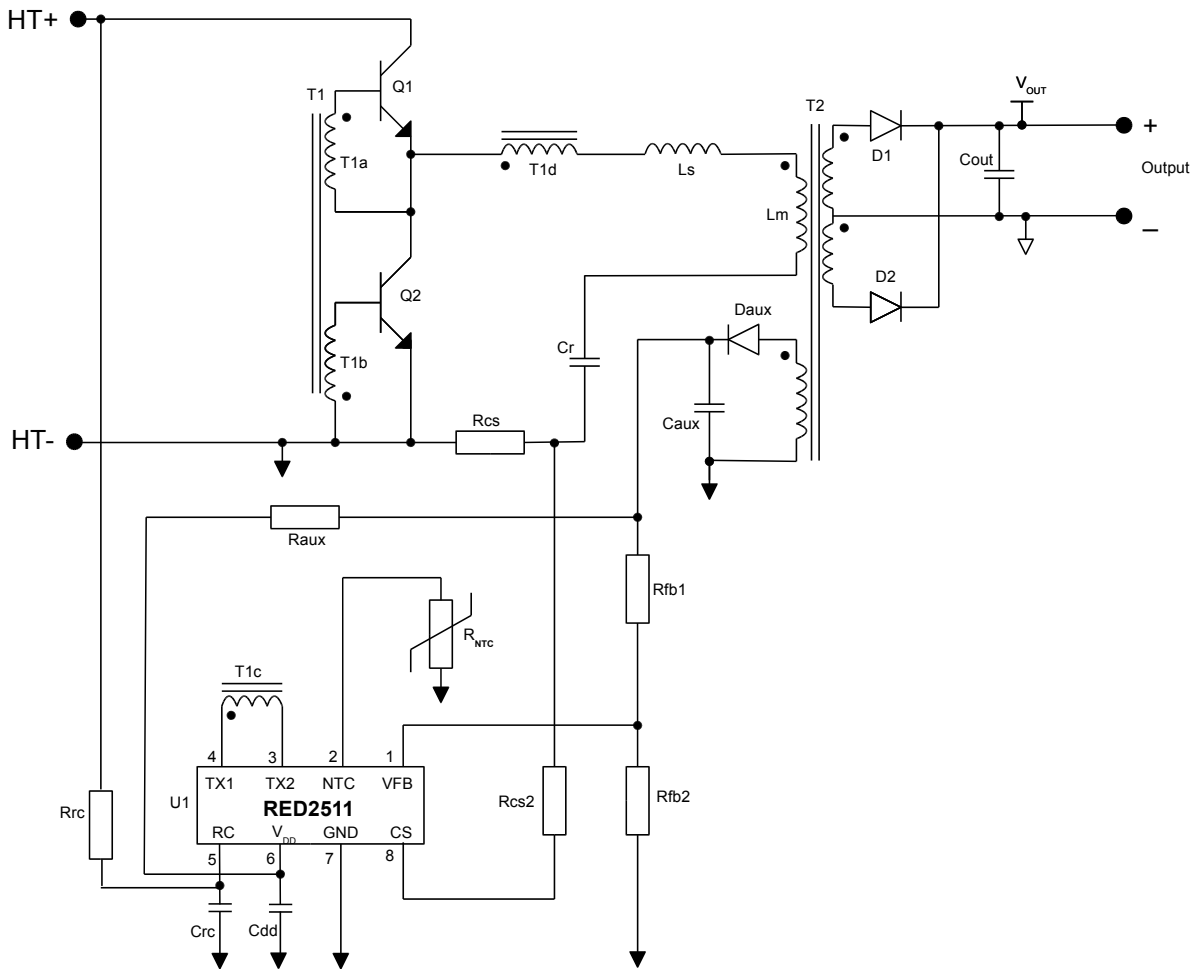

Figure 3: Typical Application Schematic: LLC converter with RED2511 PSR controller

Features

RED2511 is an advanced CMOS control IC for resonant LLC converters. The RED2511 Primary Side Regulation (PSR) control scheme accurately controls the LED current and removes the need for secondary side opto-coupler feedback, reducing cost and complexity.

RED2511 uses the CSOC (Controlled Self-Oscillating Converter) scheme to drive two low-cost bipolar transistors in a half-bridge configuration. RED2511 is optimized to work with RediSem's LLC converter topology with integrated Power Factor Correction.

Please contact RediSem for application design information for LED drivers with PFC.

Accurate Primary Side Regulation

The RED2511 PSR scheme regulates the LED drive current by modulating the converter frequency. Primary side current control enables +/-5% LED current regulation. With the LED

disconnected, the RED2511 controls the maximum output voltage and enters fault-mode operation to keep the output voltage from rising and to keep the power consumption low.

Protection Features

The IC is able to detect a number of faults that cause the IC to enter a fault mode:

- Output Open circuit (no LED connected)
- Output short circuit
- Over-temperature fault

During these fault conditions, the IC will continually attempt to re-start. Between each re-start attempt there will be 8 dummy re-starts when the IC re-starts while the converter is off.

If the output is short-circuit, the auxiliary power to the IC fails and the IC shuts down. The IC detects this and when it next re-starts, it does so at half output current. It continues to do so until the short



has been removed. If the fault is removed, the IC will automatically return to full output current.

The IC also has an instantaneous cycle-by-cycle over-current protection (OCP) level that will terminate any cycle instantaneously should the current exceed a pre-set level.

Over-temperature Protection & Shutdown

RED2511 has an NTC shutdown pin that can be used either in conjunction with a thermistor or with a logic signal. A high NTC resistance on the pin will allow the converter to run and a low NTC resistance will turn it off. Current is sourced from the NTC pin to allow simple connection to a thermistor. A small amount of hysteresis is also applied to this pin.

An internal over-temperature protection shuts down the controller if the IC temperature exceeds 125°C. The IC will restart the converter when the IC temperature drops by 15°C.

Automatic Dead-Time Control

An important feature of the Controlled Self Oscillating Converter is that the dead-time is controlled naturally. Unlike MOSFET half-bridge converters, it is not necessary to program the dead-time on RED2511. The bipolar switching transistors are turned on correctly through the self-oscillation of the converter and turned off by RED2511. This greatly simplifies the design process and improves the robustness of the LLC converter.

Capacitive Mode Protection

RED2511 includes a capacitive mode protection feature which prevents the converter from entering capacitive switching mode on a cycle-by-cycle basis by limiting the minimum frequency. This always ensures the Controlled Self Oscillating Converter continues to oscillate correctly.

IC Operation

Startup, Shutdown and re-start

Figure 4 shows typical startup waveforms for RED2511. In SLEEP mode the I_{DD} current is approximately 8uA ($I_{DD\text{SLEEP}}$). Once VDD reaches 3.7V ($V_{DD\text{START}}$) the IC enters STARTUP mode. During the initial period of approximately 40ms (2048 cycles) VDD is allowed to drop to 2.4V or rise to 3.6V. This gives time for the application to pull up the output voltage. After this the IC

enters RUN mode when the controlled Zener clamp inside the IC regulates the VDD voltage to 3.45V ($V_{DD\text{REG}}$). The IC current is now approximately 0.7mA ($I_{DD\text{REG}}$) plus any excess current required to clamp VDD to 3.45V. If VDD falls below 3.45V ($V_{DD\text{REG}}$) the Zener clamp turns off and I_{DD} reduces to 0.7mA ($I_{DD\text{REG}}$) only. If VDD falls below 2.9V ($V_{DD\text{SLEEP}}$), the IC enters SLEEP mode. In this condition I_{DD} reduces to 8uA. ($I_{DD\text{SLEEP}}$).

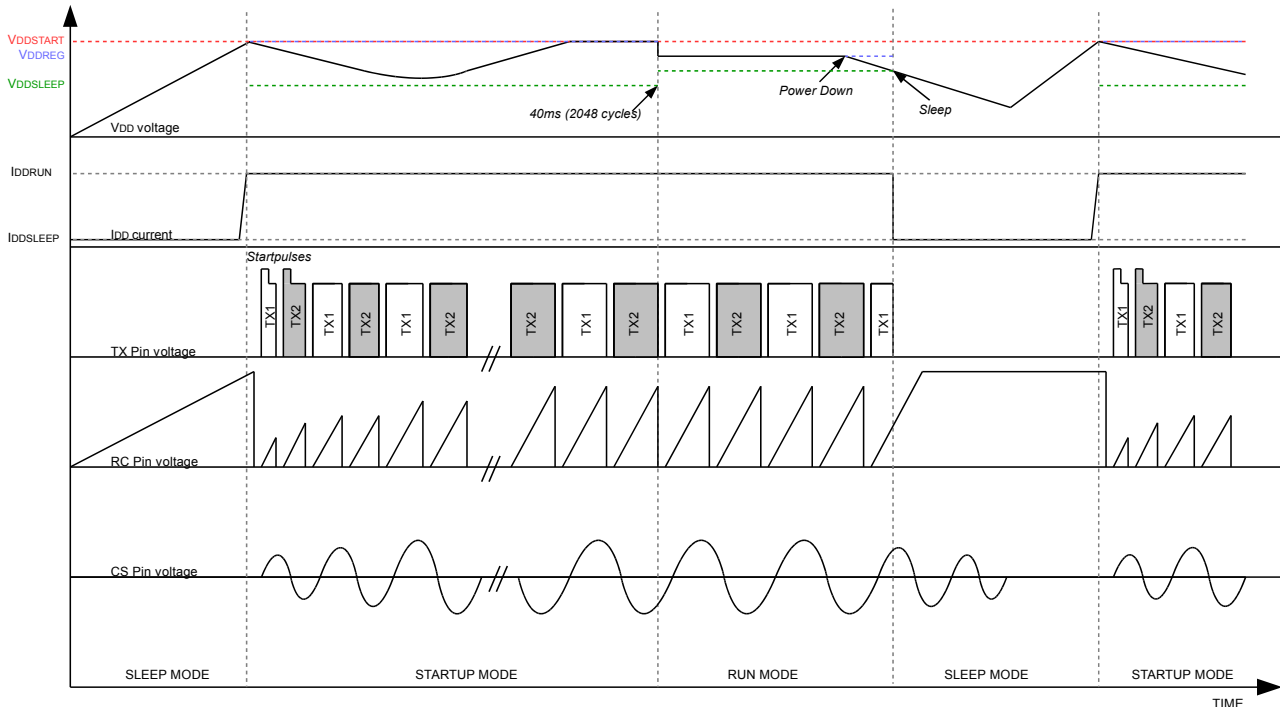

Figure 4: IC Start-up waveforms

Output stage

A diagram of the output stage can be seen in Figure 5. To start the converter oscillating the RED2511 issues start pulses through the TX pins during the first two cycles. These start pulses are 800ns long ($t_{TX\text{START}}$) and provide 28mA ($I_{TX\text{START}}$) current pulses from both TX1 and TX2 pins. After this the converter self-oscillates and no longer needs start pulses to maintain oscillation. A low

on-state NMOS transistor is used to turn the bipolar transistors off. It is controlled by the oscillator off-time. The NMOS device is turned to pull TX pin low, which switches off the corresponding bipolar transistor in the power converter half-bridge.

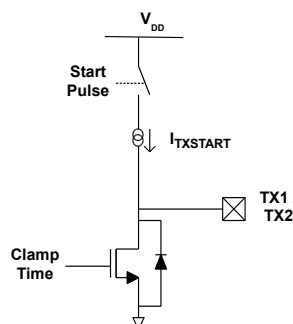

Figure 5: Output Stage

Primary Side Regulation (PSR)

The converter's output current and voltage are estimated by the RED2511 PSR scheme. Inside the IC there are two separate control loops that control the converter output current (in CC mode) and voltage (in CV mode). The RED2511 regulates the output current and voltage by controlling the frequency. An Oscillator Control

voltage is fed into the oscillator comparator to give the desired operating frequency. Figure 6 shows how the two current and voltage error amplifiers and their compensation networks are configured for a primary regulated LLC converter.

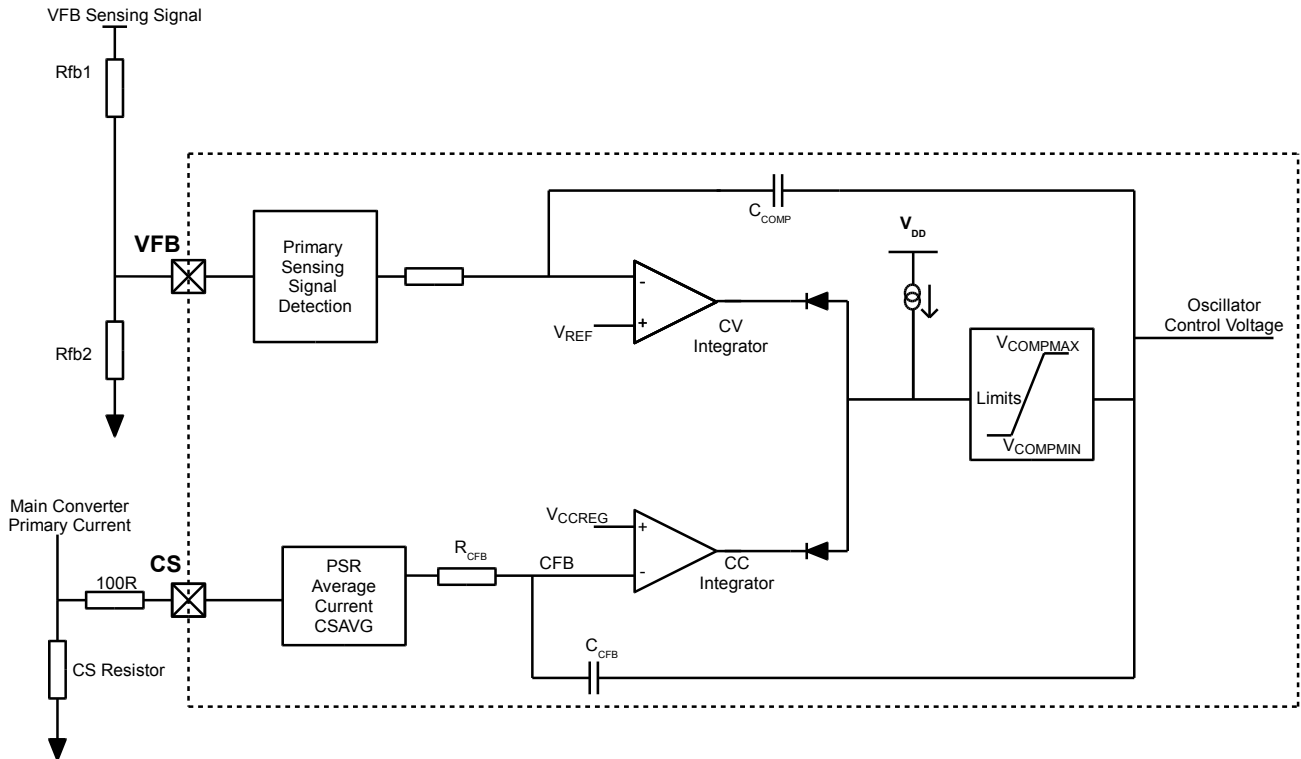

Figure 6: Error Amplifier Circuits

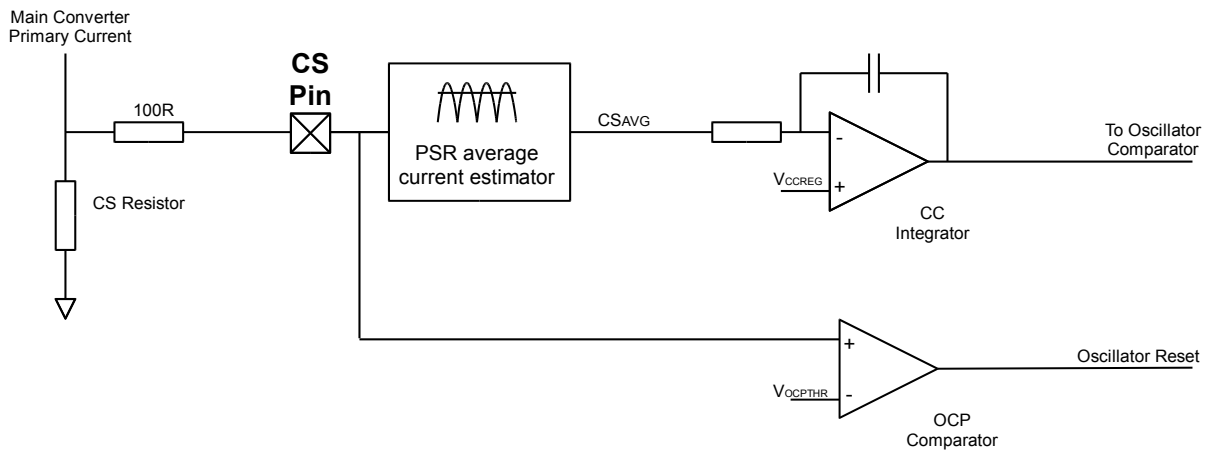

Figure 7: RED2511 Current protection and control circuits

PSR Current Control

Figure 7 shows the two current control methods used in the converter:

1. constant current (CC) regulation;
2. an instantaneous peak current limit (OCP).

PSR Average current estimation

Shown in figure 7 the signal from the CS pin is divided into two different paths. The bottom path provides peak instantaneous over-current protection (OCP) while the PSR Average Current estimation block provides the current regulation (CC) information. The voltage on the CS pin is an AC signal biased around GND. Inside the PSR block this signal is processed to provide a voltage proportional to the average converter output current.

Constant Current Regulation

The CC regulation circuit is shown in Figure 7. CC operation is defined by an internally compensated control loop. This provides a system response time of approximately 300us in a typical application. The average current regulation point, V_{CCREG} is pre-set to 150mV, referred to the CS pin.

Over Current Protection

Over-Current Protection (OCP) is an instantaneous termination of the current oscillator cycle and the transistor on-time. When a peak voltage greater than 500mV (V_{OCPTHR}) is sensed

on the CS pin the OCP comparator terminates the current oscillator on-time cycle. The oscillator is reset and the off-time begins resulting in the bipolar transistors turning off and the half-bridge commutating. This is repeated in subsequent cycles whenever the CS voltage exceeds the threshold. However, in a correctly designed converter it should not be possible to trip OCP in normal operation.

PSR Voltage Control

RED2511 features an internally compensated CV control loop to control the maximum LED converter output voltage. The VFB input senses the output voltage from an auxiliary winding on the primary side of the transformer. This signal is conditioned in the PSR block and compared to a voltage reference of 1.2V (V_{REF}) inside the IC.

In CV mode the VFB pin is regulated to V_{REF} by adjusting the internal control voltage and therefore the converter operating frequency. If the VFB pin voltage exceeds V_{REF} RED2511 will enter shutdown.

In a constant current LED application the VFB voltage will normally be below the 1.2V regulation point V_{REF} as the CC control loop determines the control voltage. If the LED voltage is too high, or the LED becomes disconnected, the CC loop is not in control and the VFB voltage will exceed 1.2V V_{REF} control voltage. At that point RED2511 will shut down and enter fault mode, re-starting regularly to check if the fault has been removed.

Oscillator

The oscillator (see Figure 8) controls the period of a converter half-cycle. Internal to the IC is an oscillator comparator that compares the voltage on the RC pin to a control voltage. The RC pin has a saw tooth type waveform and the control voltage is inversely proportional to the required frequency.

The control voltage can vary from 0.3V to 2.35V, resulting in a maximum to minimum frequency ratio of nearly 7x for any input voltage.

The timing capacitor C_{RC} may be chosen within the range 100 – 1000 pF. The recommended type is a 5% COG/NPO capacitor.

The oscillator timing resistor R_{RC} may be connected to either V_{DD} or to the rectified DC bus, V_{HT} . If connected to V_{DD} , the value of R_{RC} may be calculated using following equation:

$$F_{MIN} = \frac{1}{2 \times \left(0.8 \times 10^{-6} - R_{RC} \times C_{RC} \times \ln \left(1 - \frac{2.35}{3.45} \right) \right)}$$

This equation gives the lowest possible operating frequency of the converter.

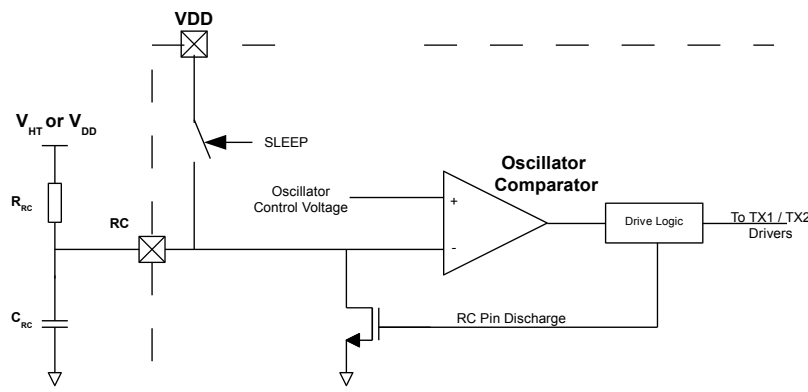

Figure 8: Oscillator circuit

Oscillator Feed-forward Compensation

The oscillator may optionally include feed-forward compensation. Feed-forward compensation is recommended to minimise the line frequency ripple on the output. To apply the feed-forward compensation, the oscillator pull-up resistor R_{RC} is connected to the DC bulk supply V_{HT} instead of V_{DD} . The value may be calculated as a function of the DC bulk voltage using the following equation:

$$F_{MIN} = \frac{1}{2 \times \left(0.8 \times 10^{-6} + R_{RC} \times C_{RC} \times \frac{2.35}{V_{HT}} \right)}$$

To assist feed-forward applications, a switch is provided which connects the V_{DD} pin to the RC pin while the controller is in SLEEP. This allows the R_{RC} resistor to pull up the V_{DD} supply for start up.

NTC pin

RED2511 features an NTC pin to interface with an external over-temperature circuit as shown in figure 9. The NTC pin features a current source to bias an external circuit featuring a Negative Temperature Coefficient resistor (NTC). A comparator determines the NTC pin trip point. When the IC is in SLEEP mode the NTC pin is clamped to GND.

The external NTC circuit should be biased so that under normal operation the resistance on the NTC pin is above the trip-point R_{NTC} (V_{NTC}/I_{NTC}). The NTC pin is blanked for approximately 5ms at IC start-up to avoid any spurious triggering while the

external NTC circuit is settling. When the converter heats up the NTC resistance decreases. After the NTC resistance drops below the trip-point R_{NTC} the IC will shut the converter down and restart if the converter has cooled down and the NTC pin resistance has increased.

With the appropriate selection and placement of the NTC circuit it is possible to achieve accurate over-temperature shutdown anywhere on the LED converter PCB.

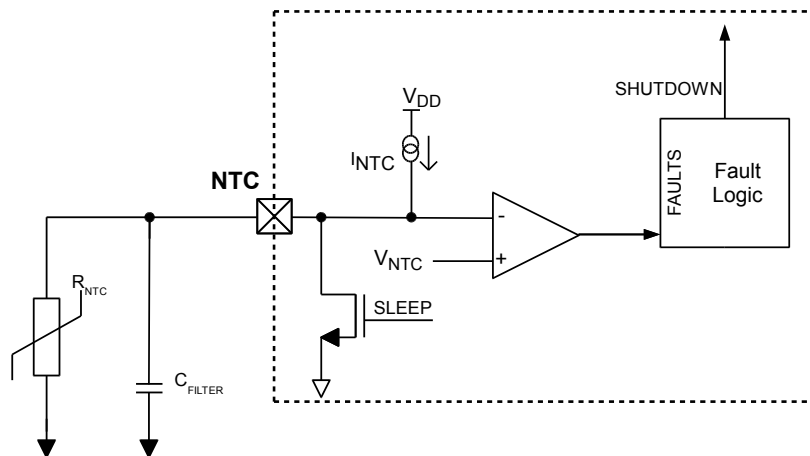

Figure 9: RED2511 NTC pin circuit

ABSOLUTE MAXIMUM RATINGS

CAUTION: Permanent damage may result if a device is subjected to operating conditions at or in excess of absolute maximum ratings.

Parameter	Symbol	Condition	Min	Max	Unit
Supply voltage	V _{DD}	SLEEP mode: self-limited by IC start-up (V _{DDSTART})	-0.5	4.5	V
Supply voltage	V _{DD}	RUN mode: Self-limited by internal shunt regulator	-0.5	4.0	V
Supply current	I _{DD}		0	10	mA
Input/output voltages	V _{IO}		-0.5	V _{DD} + 0.5	V
Input/output currents	I _{IO}		-10	10	mA
Junction temperature	T _J	T _{J_MAX} limited by OTP (T _{OTPS_MAX})	-25	+135	°C
Storage temperature	T _P		-25	+125	°C
Lead temperature	T _L	Soldering, 10 s		260	°C
ESD withstand		Human body model, JESD22-A114		2	kV
		Capacitive Discharge Model		500	V

NORMAL OPERATING CONDITIONS

Unless otherwise stated, electrical characteristics are defined over the range of normal operating conditions. Functionality and performance is not defined when a device is subjected to conditions outside this range and device reliability may be compromised.

Parameter	Symbol	Condition	Min	Typ	Max	Unit
Minimum supply current	I _{DDMIN}		0.8	1.0	1.2	mA
Junction temperature	T _J		-25	25	125	°C

ELECTRICAL CHARACTERISTICS

Unless otherwise stated:

- Min and Max electrical characteristics apply over normal operating conditions.
- Typical electrical characteristics apply at T_J = T_{J(TYP)} and I_{DD} = I_{DDREG(TYP)}.
- The chip is operating in RUN mode.
- Voltages are specified relative to the GND pin.

VDD Pin

Parameter	Symbol	Condition	Min	Typ	Max	Unit
Supply voltage	V _{DDSTART}	Enter RUN mode from SLEEP	3.2	3.7	4.2	V
	V _{DDREG}	I _{DD} < I _{DDSHUNT}	3.25	3.45	3.65	V
	V _{DDSLEEP}	To enter SLEEP mode	2.7	2.9	3.1	V
Supply current	I _{DDREG}	In RUN mode, V _{DD} < V _{DDREG}		0.7	0.8	mA
	I _{DDSLEEP}	In SLEEP mode		8	12	µA
	I _{DDSHUNT}	V _{DD} shunt regulator max current			8	mA



RED2511 LED LLC Controller

VFB Pin

Parameter	Symbol	Condition	Min	Typ	Max	Unit
VFB threshold voltage	V _{REF}	T _J = 0°C to 85°C, V _{DD} =3.45V	1.15	1.20	1.25	V

CS Pin

Parameter	Symbol	Condition	Min	Typ	Max	Unit
Constant current regulation	V _{CCREG}	DC CS signal. T _J = 0°C to 85°C	146	150	154	mV
Instantaneous over-current protection threshold	V _{OCPTHR}			500		mV

RC Pin

Parameter	Symbol	Condition	Min	Typ	Max	Unit
External capacitor range	C _{RC}		100		1000	pF
Oscillator Frequency Variation	ΔF _{RC} /F _{RC} *	T _J = 0°C to 85°C, C _{RC} =330pF, V _{DD} =3.45V, min frequency			5	%
Oscillator reset time	T _{RCRST}			0.7		μs

NTC Pin

Parameter	Symbol	Condition	Min	Typ	Max	Unit
NTC pin threshold	R _{NTC}	Trip fault: NTC resistance high→low (T _J = 25°C)	14.0	15.5	17.0	kΩ
	ΔR _{NTC} *	Fault recovery hysteresis: NTC resistance low→high		2		kΩ
NTC pin temperature coefficient	θ _{RNTC} *	NTC pin resistance temperature coefficient *		+0.145		% / °C

TX1, TX2 Pins

Parameter	Symbol	Condition	Min	Typ	Max	Unit
On-state resistance	R _{TXON}			1.0	1.5	Ω
TX pin clamp current	I _{TXCLAMP} *	TX pin frequency >30kHz			800	mA
Start-pulse output current	I _{TXSTART}	TX pin voltage 2V		28		mA
Start-pulse width	T _{TXSTART}			800		ns

Over-Temperature Protection (OTP) *

Parameter	Symbol	Condition	Min	Typ	Max	Unit
Over-Temperature Protection threshold	T _{OTPS}	At silicon junction	115	125	135	°C
Over-Temperature Protection reset hysteresis	T _{OTP_HYS}	At silicon junction		15		°C

*: not tested in production

PACKAGE INFORMATION

Package Dimensions

SO8N package dimensions are shown below. All units are in mm.

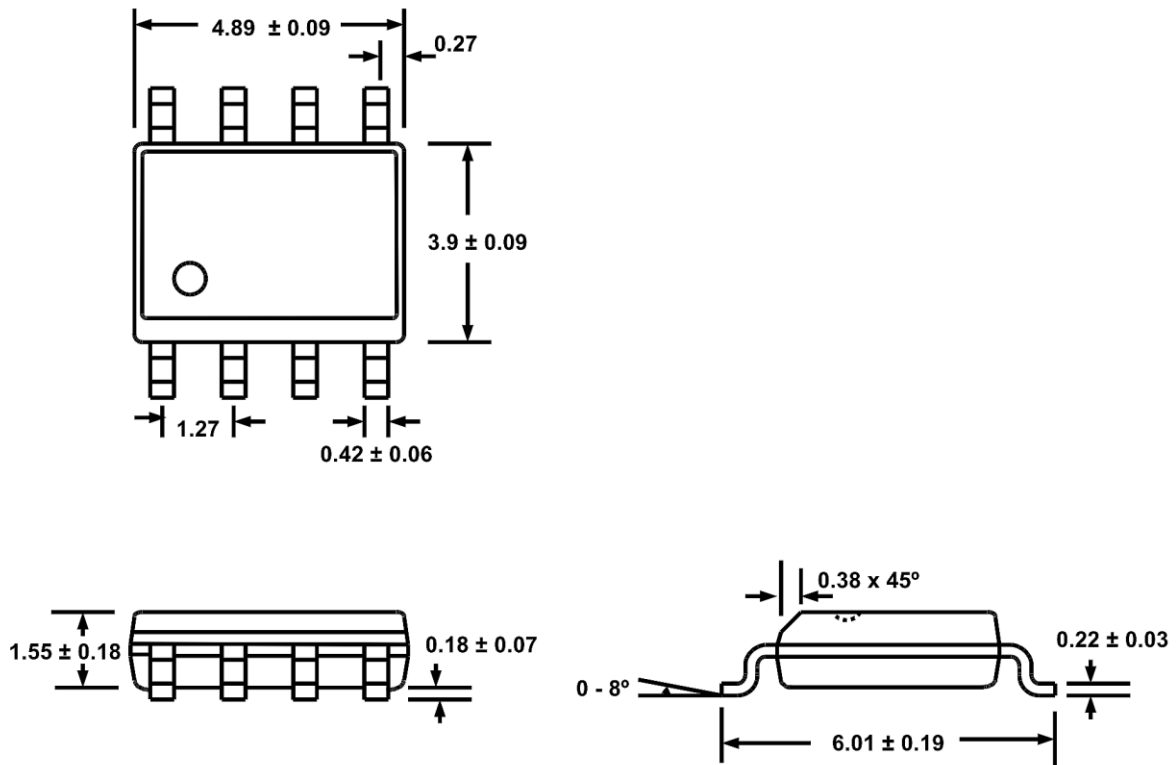

Available packages

Package type	Part number	Moisture Sensitivity Level (MSL)	Packaging	Thermal Resistances		
				Junction - Lead	θ_{JL}	30°C/W
SO8	RED2511AD-TR13	3 (JEDEC J-STD-020)	Tape and reel 2500pcs/13" reel	Junction - Ambient	θ_{JA}	150°C/W

Package Marking

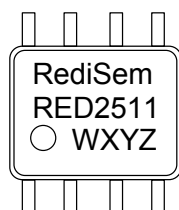

SO8N top-side marking for RED2511

RED2511= Part Number

WXYZ= Lot Code, e.g. AAAA, AAAB



Status

The status of this Datasheet is shown in the footer.

Datasheet Status	Product Status	Definition
Preview	In development	The Datasheet contains target specifications relating to design and development of the described IC product.
Preliminary	In qualification	The Datasheet contains preliminary specifications relating to functionality and performance of the described IC product.
Production	In production	The Datasheet contains specifications relating to functionality and performance of the described IC product which are supported by testing during development and production.

Contact Details

RediSem Ltd.
301-302 IC Development Centre
No 6 Science Park West Avenue
Hong Kong Science & Technology Park
Shatin, New Territories
Hong Kong

Tel. +852 2607 4141
Fax. +852 2607 4140
Email: info@redisem.com
Web: www.redisem.com

Disclaimer

The product information provided herein is believed to be accurate and is provided on an “as is” basis. RediSem Ltd assumes no responsibility or liability for the direct or indirect consequences of use of the information in respect of any infringement of patents or other rights of third parties. RediSem Ltd does not grant any licence under its patent or intellectual property rights or the rights of other parties.

Any application circuits described herein are for illustrative purposes only. Specifications are subject to change without notice. In respect of any application of the product described herein RediSem Ltd expressly disclaims all warranties of any kind, whether express or implied, including, but not limited to, the implied warranties of merchantability, fitness for a particular purpose and non-infringement of third party rights. No advice or information, whether oral or written, obtained from RediSem Ltd shall create any warranty of any kind. RediSem Ltd shall not be liable for any direct, indirect, incidental, special, consequential or exemplary damages, howsoever caused including but not limited to, damages for loss of profits, goodwill, use, data or other intangible losses.

The products and circuits described herein are subject to the usage conditions and end application exclusions as outlined in RediSem Ltd Terms and Conditions of Sale.

RediSem Ltd reserves the right to change specifications without notice. To obtain the most current product information available visit www.redisem.com or contact us at the address shown above.