

## LLC Controller for CV LED Drivers

### Features

- Advanced LLC Controller IC for high efficiency low-cost Constant voltage (CV) LED Drivers
- Resonant half-bridge for excellent EMI using robust low-cost bipolar transistors
- Optimised for optocoupler-based CV applications using secondary sensing
- 50% duty cycle, variable frequency control of resonant half-bridge
- +/-5% accurate limiting of output current using primary sensing regulation (PSR)
- Boost current feature to ensures reliable startup with constant power loads
- Protection modes:
  - Overload output including short-circuit
  - No-Load output
  - Over-temperature (internal or NTC)
- Low standby power
- Small SO8 IC package



SO8

### Applications

- Passive PFC CV LED drivers 20W - 100W
- Active PFC CV LED drivers 40W - 300W

### Order code

Part Number	Package	Packaging
RED2541AD-TR13	SO8	Tape and reel

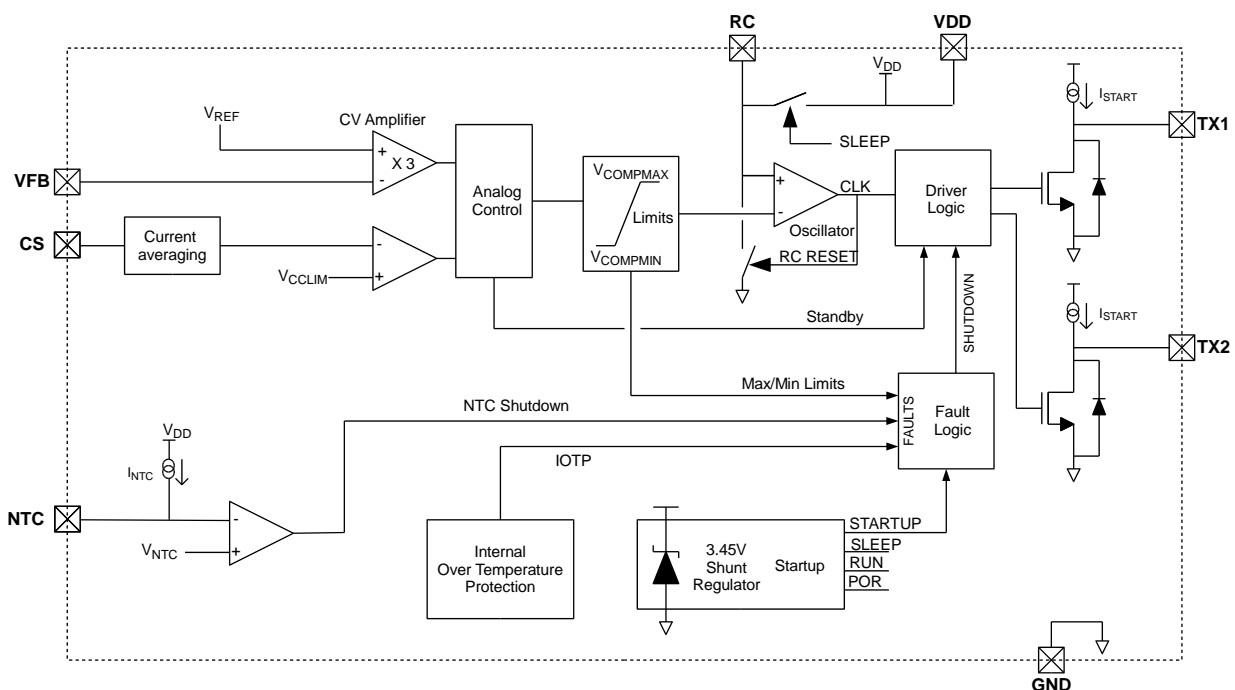

Figure 1: Block diagram

## Device Pins

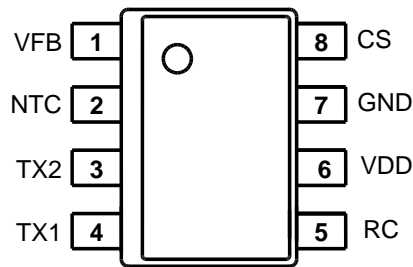

Figure 2: SO8 pin connections (top view)

## Pin Functions

Pin #	Name	Function
1	VFB	Feedback input for output voltage regulation. Connect to optocoupler feedback.
2	NTC	Shutdown pin that can be used for over-temperature protection with an external NTC resistor. A voltage of $<V_{NTC}$ will shut the IC down. Pin also includes a current source.
3	TX2	Output to control transformer.
4	TX1	Output to control transformer.
5	RC	External RC network sets the minimum [full power] switching frequency.
6	VDD	IC Power Supply pin – nominally 3.45V
7	GND	Chip ground.
8	CS	PSR Current Sense input provides output current regulation and cycle-by-cycle over-current protection. The CS pin is connected to the half-bridge current sense resistor

## Typical Application

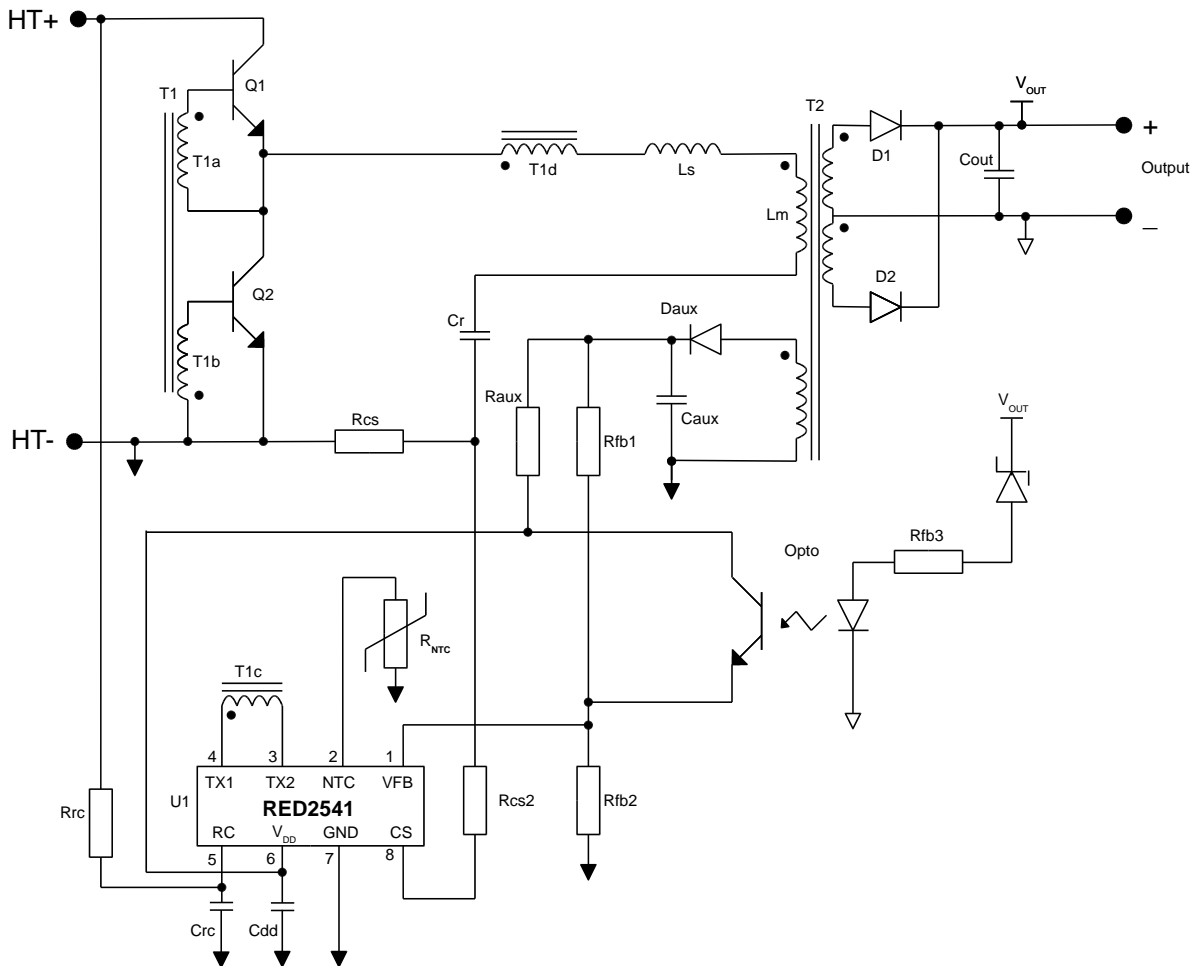

Figure 3: Typical Application Schematic: LLC converter with RED2541 CV controller

## Features

RED2541 is an advanced CMOS control IC for resonant converters such as LC, LLC and LCC. The RED2541 control scheme accurately controls the driver output voltage by means of secondary side feedback employing an amplifier and optocoupler. The IC also accurately controls the driver output current with RediSem's PSR technique, reducing cost, complexity and power consumption.

RED2541 uses the CSOC (Controlled Self-Oscillating Converter) scheme to drive two low-cost bipolar transistors in a half-bridge configuration. RED2541 is optimized to work with RediSem's resonant converter topology with integrated Power Factor Correction.

The RED2541 PSR scheme regulates the LED drive current by modulating the converter frequency. Primary side current control enables very accurate overload regulation and detection.

The IC enters a controlled burst-mode operation at light load, minimising the converter's input power consumption. The point at which the IC enters burst mode is pre-set to a value derived from the primary-side current to keep the output voltage from rising and to keep the power consumption low.

### Protection Features

The IC is able to detect a number of faults that cause the IC to enter a fault mode:

- Output open circuit (no LED connected)
- Output overload
- Output short circuit
- Over-temperature fault

During these fault conditions, the IC will continually attempt to re-start. Depending on the fault, there can be 8 dummy re-starts between re-start attempts when the IC re-starts while the converter remains off.



If the output is short-circuit, the auxiliary power to the IC fails and the IC shuts down. The IC detects this and when it next re-starts, it does so at half output current. It continues to do so until the short has been removed. If the fault is removed, the IC will automatically return to full output current.

The IC also has an instantaneous cycle-by-cycle over-current protection (OCP) level that will terminate any cycle instantaneously should the current exceed a pre-set level.

### **Over-temperature Protection & Shutdown**

RED2541 has an NTC shutdown pin that can be used either in conjunction with a thermistor or with a logic signal. A high NTC resistance on the pin will allow the converter to run and a low NTC resistance will turn it off. Current is sourced from the NTC pin to allow simple connection to a thermistor. A small amount of hysteresis is also applied to this pin.

An internal over-temperature protection shuts down the controller if the IC temperature exceeds

125°C. The IC will restart the converter when the IC temperature drops by 8°C.

### **Automatic Dead-Time Control**

An important feature of the Controlled Self Oscillating Converter is that the dead-time is controlled naturally. Unlike MOSFET half-bridge converters, it is not necessary to program the dead-time on RED2541. The bipolar switching transistors are turned on correctly through the self-oscillation of the converter and turned off by RED2541. This greatly simplifies the design process and improves the robustness of the LLC converter.

### **Capacitive Mode Protection**

RED2541 includes a capacitive mode protection feature which prevents the converter from entering capacitive switching mode on a cycle-by-cycle basis by limiting the minimum frequency. This always ensures the Controlled Self Oscillating Converter continues to oscillate correctly.

## IC Operation

### Startup, Shutdown and re-start

Figure 4 shows typical startup waveforms for RED2541. In SLEEP mode the  $I_{DD}$  current is approximately 8uA ( $I_{DD\text{SLEEP}}$ ). Once VDD reaches 3.7V ( $V_{DD\text{START}}$ ) the IC enters STARTUP mode. During the initial period of approximately 40ms (2048 cycles) VDD is allowed to drop to 2.4V or rise to 3.6V. This gives time for the application to pull up the output voltage. After this the IC

enters RUN mode when the controlled Zener clamp inside the IC regulates the VDD voltage to 3.45V ( $V_{DD\text{REG}}$ ). The IC current is now approximately 0.7mA ( $I_{DD\text{REG}}$ ) plus any excess current required to clamp VDD to 3.45V. If VDD falls below 3.45V ( $V_{DD\text{REG}}$ ) the Zener clamp turns off and  $I_{DD}$  reduces to 0.7mA ( $I_{DD\text{REG}}$ ) only. If VDD falls below 2.9V ( $V_{DD\text{SLEEP}}$ ), the IC enters SLEEP mode. In this condition  $I_{DD}$  reduces to 8uA ( $I_{DD\text{SLEEP}}$ ).

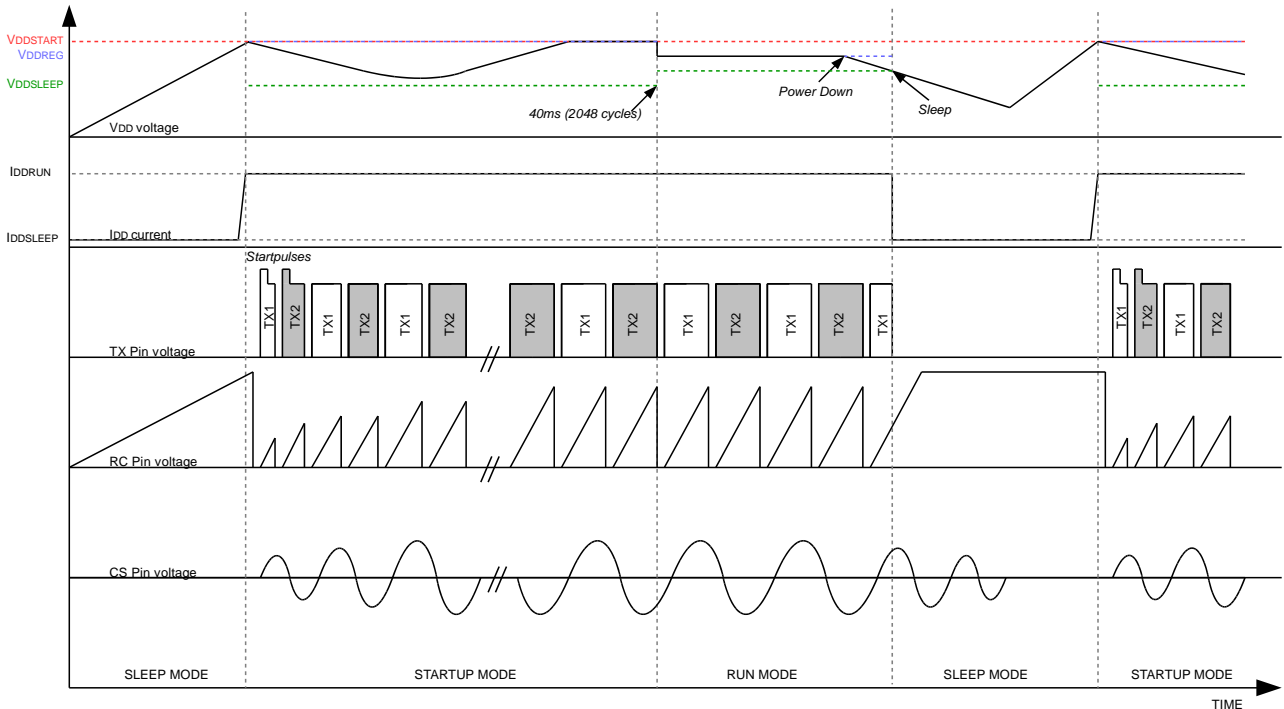

Figure 4: IC Start-up waveforms

### Output stage

A diagram of the output stage can be seen in Figure 5. To start the converter oscillating the RED2541 issues start pulses through the TX pins during the first two cycles. These start pulses are 800ns long ( $t_{TX\text{START}}$ ) and provide 28mA ( $I_{TX\text{START}}$ ) current pulses from both TX1 and TX2 pins. After this the converter self-oscillates and no longer needs start pulses to maintain oscillation. A low

on-state NMOS transistor is used to turn the bipolar transistors off. It is controlled by the oscillator off-time. The NMOS device is turned to pull TX pin low, which switches off the corresponding bipolar transistor in the power converter half-bridge.

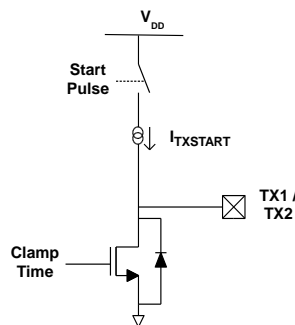

Figure 5: Output Stage

## Voltage and current Regulation

The converter's output voltage and current are controlled by two independent amplifiers within the IC, as shown in figure 6. Inside the IC there are two separate control loops that control the converter output voltage (in normal operation) and output current (during pullup or overload). The RED2541 regulates the output current and voltage

by controlling the frequency. An Oscillator Control Voltage is fed into the oscillator comparator to give the desired operating frequency. Figure 6 shows how the two current and voltage error amplifiers and their compensation networks are configured for a primary regulated resonant converter.

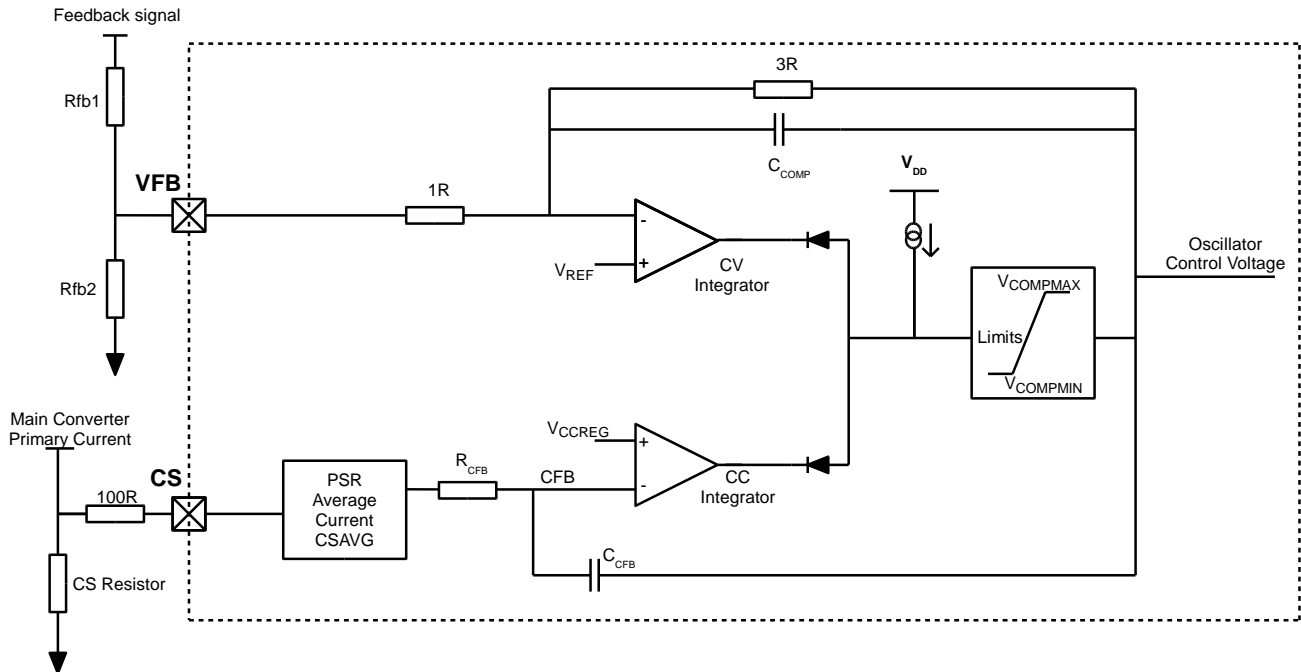

Figure 6: Error Amplifier Circuits

## Voltage Control

The VFB pin of the RED2541 is internally connected to a x3 amplifier. The voltage on the VFB pin is compared to the reference voltage of 1.2V and the difference is multiplied by a factor of 3 and is then fed into the oscillator. This can be seen in figure 6 where the 1R and 3R resistors control the amplifier gain. There is also a small amount of high frequency roll off to minimise disturbance from high frequency noise. An external control loop using a secondary side reference (e.g. TL431) and an optocoupler is typically used to complete the control loop.

## Light loads

The IC has a burst mode that is used to lower the input power at light loads so that standby power is minimised. The standby point is usually set to 5-10% of rated load current. enters a controlled burst-mode operation at light load, by switching in

and out of STANDBY, thereby minimising the converter's input power consumption.

## Standby Entry

RED2541 will enter standby when either the IC reaches its maximum allowable operating frequency; or when a low load condition is detected. When the IC detects this condition, it goes into standby. In standby mode, the converter is held in the off condition, with the IC waiting for a standby exit signal

## Standby Exit

During standby, the output voltage will fall slightly. The control loop then demands more power by turning the optocoupler off slightly, thereby lowering the voltage on the VFB pin. When the IC senses this, the controller will exit out of standby and begin the start sequence. The converter will again deliver power to the load and the IC will remain out of standby for a while until the load falls again, when the IC re-enters standby.

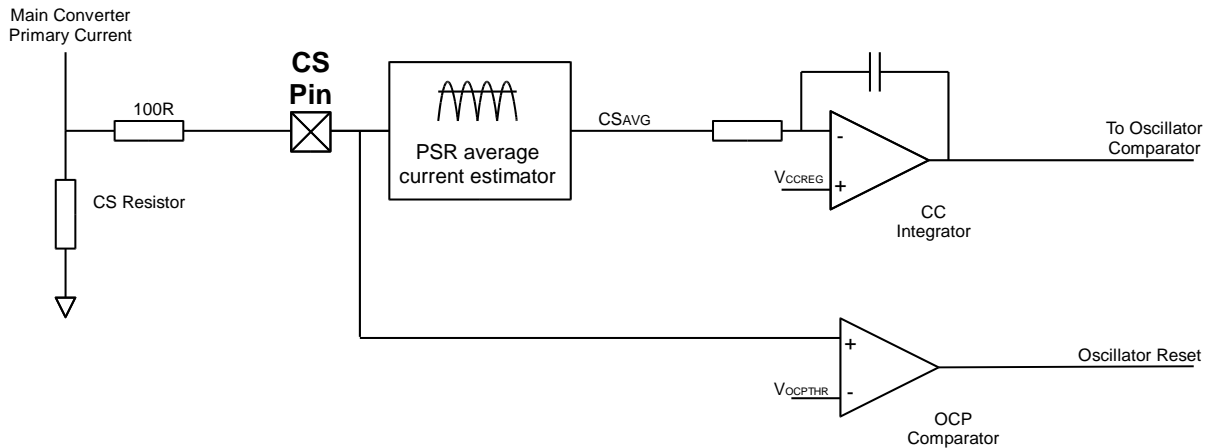

Figure 7: RED2541 Current protection and control circuits

## PSR Current Control

Current regulation is used during pullup and during overload conditions. Figure 7 shows the two current control methods used in the converter:

1. constant current (CC) regulation;
2. an instantaneous peak current limit (OCP).

## PSR Average current estimation

Shown in figure 7 the signal from the CS pin is divided into two different paths. The bottom path provides peak instantaneous over-current protection (OCP) while the PSR Average Current estimation block provides the current regulation (CC) information. The voltage on the CS pin is an AC signal biased around GND. Inside the PSR block this signal is processed to provide a voltage proportional to the average converter output current.

## Constant Current Regulation

The CC regulation circuit is shown in Figure 7. CC operation is defined by an internally compensated

control loop. This provides a system response time of approximately 300us in a typical application. The average current regulation point,  $V_{CCREG}$  is pre-set to 100mV, referred to the CS pin.

## Over Current Protection

Over-Current Protection (OCP) is an instantaneous termination of the current oscillator cycle and the transistor on-time. When a peak voltage greater than 300mV ( $V_{OCPTHR}$ ) is sensed on the CS pin the OCP comparator terminates the current oscillator on-time cycle. The oscillator is reset and the off-time begins resulting in the bipolar transistors turning off and the half-bridge commutating. This is repeated in subsequent cycles whenever the CS voltage exceeds the threshold. However, in a correctly designed converter it should not be possible to trip OCP in normal operation.

## Oscillator

The oscillator (see Figure 8) controls the period of a converter half-cycle. Internal to the IC is an oscillator comparator that compares the voltage on the RC pin to a control voltage. The RC pin has a saw tooth type waveform and the control voltage is inversely proportional to the required frequency.

The control voltage can vary from 0.3V to 2.35V, resulting in a maximum to minimum frequency ratio of nearly 7x for any input voltage.

The timing capacitor  $C_{RC}$  may be chosen within the range 100 – 1000 pF. The recommended type is a 5% COG/NPO capacitor.

The oscillator timing resistor  $R_{RC}$  may be connected to either  $V_{DD}$  or to the rectified DC bus,  $V_{HT}$ . If connected to  $V_{DD}$ , the value of  $R_{RC}$  may be calculated using following equation:

$$F_{MIN} = \frac{1}{2 \times \left( 0.8 \times 10^{-6} - R_{RC} \times C_{RC} \times \ln \left( 1 - \frac{2.35}{3.45} \right) \right)}$$

This equation gives the lowest possible operating frequency of the converter.

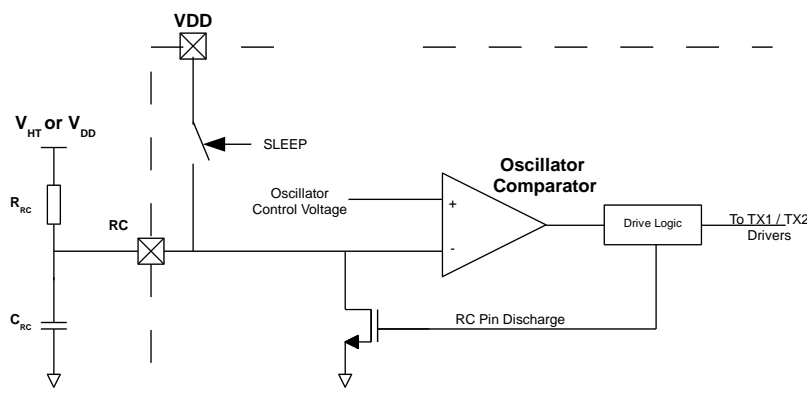

Figure 8: Oscillator circuit

## Oscillator Feed-forward Compensation

The oscillator may optionally include feed-forward compensation. Feed-forward compensation is recommended to minimise the line frequency ripple on the output. To apply the feed-forward compensation, the oscillator pull-up resistor  $R_{RC}$  is connected to the DC bulk supply  $V_{HT}$  instead of  $V_{DD}$ . The value may be calculated as a function of the DC bulk voltage using the following equation:

$$F_{MIN} = \frac{1}{2 \times \left( 0.8 \times 10^{-6} + R_{RC} \times C_{RC} \times \frac{2.35}{V_{HT}} \right)}$$

To assist feed-forward applications, a switch is provided which connects the VDD pin to the RC pin while the controller is in SLEEP. This allows the  $R_{RC}$  resistor to pull up the VDD supply for start up.



## NTC pin

RED2541 features an NTC pin to interface with an external over-temperature circuit as shown in figure 9. The NTC pin features a current source to bias an external circuit featuring a Negative Temperature Coefficient resistor (NTC). A comparator determines the NTC pin trip point. When the IC is in SLEEP mode the NTC pin is clamped to GND.

The external NTC circuit should be biased so that under normal operation the resistance on the NTC pin is above the trip-point  $R_{NTC}$  ( $V_{NTC}/I_{NTC}$ ). The NTC pin is blanked for approximately 5ms at IC start-up to avoid any spurious triggering while the

external NTC circuit is settling. When the converter heats up the NTC resistance decreases. After the NTC resistance drops below the trip-point  $R_{NTC}$  the IC will shut the converter down and restart if the converter has cooled down and the NTC pin resistance has increased.

With the appropriate selection and placement of the NTC circuit it is possible to achieve accurate over-temperature shutdown anywhere on the LED converter PCB.

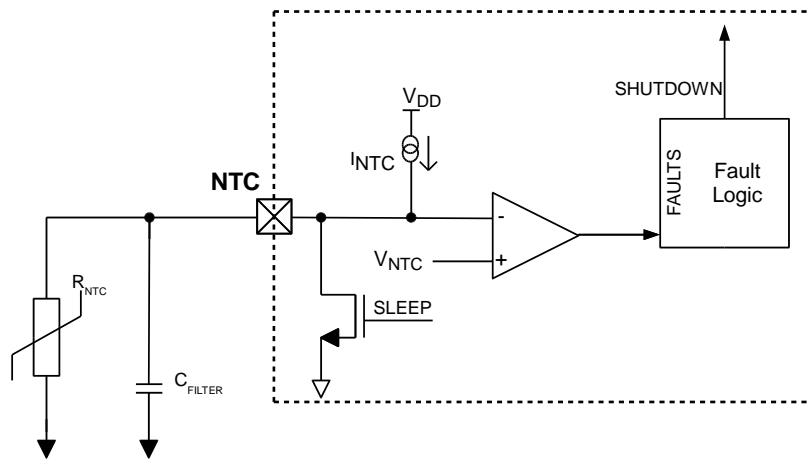

Figure 9: RED2541 NTC pin circuit

## ABSOLUTE MAXIMUM RATINGS

CAUTION: Permanent damage may result if a device is subjected to operating conditions at or in excess of absolute maximum ratings.

Parameter	Symbol	Condition	Min	Max	Unit
Supply voltage	V <sub>DD</sub>	SLEEP mode: self-limited by IC start-up (V <sub>DDSTART</sub> )	-0.5	4.5	V
Supply voltage	V <sub>DD</sub>	RUN mode: Self-limited by internal shunt regulator	-0.5	4.0	V
Supply current	I <sub>DD</sub>		0	10	mA
Input/output voltages	V <sub>IO</sub>		-0.5	V <sub>DD</sub> + 0.5	V
Input/output currents	I <sub>IO</sub>		-10	10	mA
Junction temperature	T <sub>J</sub>	T <sub>J_MAX</sub> limited by OTP (T <sub>OTPS_MAX</sub> )	-20	+135	°C
Storage temperature	T <sub>P</sub>		-20	+125	°C
Lead temperature	T <sub>L</sub>	Soldering, 10 s		260	°C
ESD withstand		Human body model, JESD22-A114		2	kV
		Capacitive Discharge Model		500	V

## NORMAL OPERATING CONDITIONS

Unless otherwise stated, electrical characteristics are defined over the range of normal operating conditions. Functionality and performance is not defined when a device is subjected to conditions outside this range and device reliability may be compromised.

Parameter	Symbol	Condition	Min	Typ	Max	Unit
Minimum supply current	I <sub>DDMIN</sub>		0.8	1.0	1.2	mA
Junction temperature	T <sub>J</sub>		-20	25	125	°C

## ELECTRICAL CHARACTERISTICS

Unless otherwise stated:

- Min and Max electrical characteristics apply over normal operating conditions.
- Typical electrical characteristics apply at T<sub>J</sub> = T<sub>J(TYP)</sub> and I<sub>DD</sub> = I<sub>DDREG(TYP)</sub>.
- The chip is operating in RUN mode.
- Voltages are specified relative to the GND pin.

### VDD Pin

Parameter	Symbol	Condition	Min	Typ	Max	Unit
Supply voltage	V <sub>DDSTART</sub>	Enter RUN mode from SLEEP	3.2	3.7	4.2	V
	V <sub>DDREG</sub>	I <sub>DD</sub> < I <sub>DDSHUNT</sub>	3.25	3.45	3.65	V
	V <sub>DDSLEEP</sub>	To enter SLEEP mode	2.7	2.9	3.1	V
Supply current	I <sub>DDREG</sub>	In RUN mode, V <sub>DD</sub> < V <sub>DDREG</sub>		0.7	0.8	mA
	I <sub>DDSLEEP</sub>	In SLEEP mode		8	12	μA
	I <sub>DDSHUNT</sub>	VDD shunt regulator max current			8	mA



# RED2541 LED LLC Controller

## VFB Pin

Parameter	Symbol	Condition	Min	Typ	Max	Unit
VFB threshold voltage	V <sub>REF</sub>	T <sub>J</sub> = 0°C to 85°C, V <sub>DD</sub> =3.45V	1.15	1.20	1.25	V
VFB amplifier gain				3		

## CS Pin

Parameter	Symbol	Condition	Min	Typ	Max	Unit
Constant current regulation	V <sub>CCREG</sub>	DC CS signal. T <sub>J</sub> = 0°C to 85°C	96	100	104	mV
Instantaneous over-current protection threshold	V <sub>OCP<sub>THR</sub></sub>			300		mV

## RC Pin

Parameter	Symbol	Condition	Min	Typ	Max	Unit
External capacitor range	C <sub>RC</sub>		100		1000	pF
Oscillator Frequency Variation	$\Delta F_{RC}/F_{RC}$ *	T <sub>J</sub> = 0°C to 85°C, C <sub>RC</sub> =330pF, V <sub>DD</sub> =3.45V, min frequency			5	%
Oscillator reset time	T <sub>R<sub>CRST</sub></sub>			0.7		μs

## NTC Pin

Parameter	Symbol	Condition	Min	Typ	Max	Unit
NTC pin threshold	R <sub>NTC</sub>	Trip fault: NTC resistance high→low (T <sub>J</sub> = 25°C)	14.0	15.5	17.0	kΩ
	$\Delta R_{NTC}$ *	Fault recovery hysteresis: NTC resistance low→high		2		kΩ
NTC pin temperature coefficient	$\theta R_{NTC}$ *	NTC pin resistance temperature coefficient *		+0.145		% / °C

## TX1, TX2 Pins

Parameter	Symbol	Condition	Min	Typ	Max	Unit
On-state resistance	R <sub>TXON</sub>			1.0	1.5	Ω
TX pin clamp current	I <sub>TXCLAMP</sub> *	TX pin frequency >30kHz			800	mA
Start-pulse output current	I <sub>TXSTART</sub>	TX pin voltage 2V		28		mA
Start-pulse width	T <sub>TXSTART</sub>			800		ns

## Over-Temperature Protection (OTP)\*

Parameter	Symbol	Condition	Min	Typ	Max	Unit
Over-Temperature Protection threshold	T <sub>OTPS</sub>	At silicon junction	115	125	135	°C
Over-Temperature Protection reset hysteresis	T <sub>OTP_HYS</sub>	At silicon junction		8		°C

\*: not tested in production

## PACKAGE INFORMATION

### Package Dimensions

SO8N package dimensions are shown below. All units are in mm.

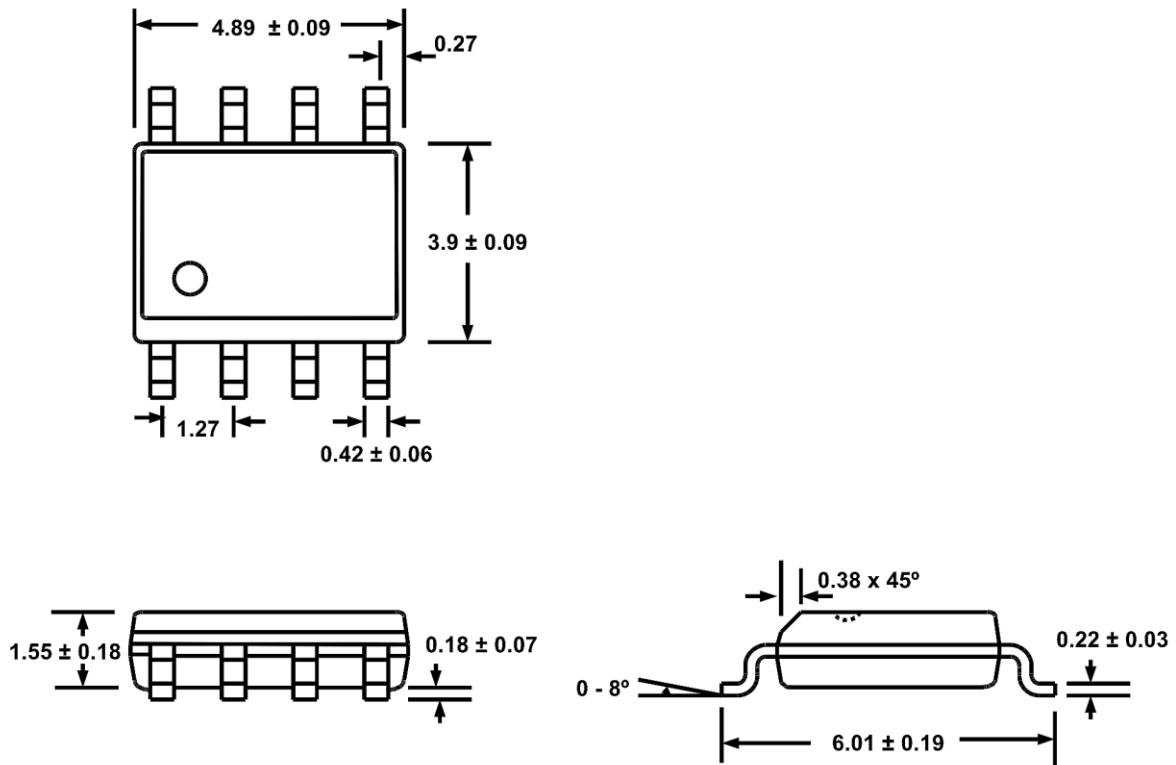

## Available packages

Package type	Part number	Moisture Sensitivity Level (MSL)	Packaging
SO8	RED2541AD-TR13	3 (JEDECJ-STD-020)	Tape and reel 2500 / 13" reel

## Package Marking

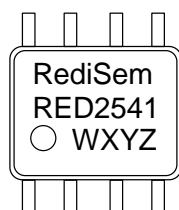

### SO8N top-side marking for RED2541

RED2511= Part Number

WXYZ= Lot Code, e.g. AAAA, AAAB



## Status

The status of this Datasheet is shown in the footer.

Datasheet Status	Product Status	Definition
Preview	In development	The Datasheet contains target specifications relating to design and development of the described IC product.
Preliminary	In qualification	The Datasheet contains preliminary specifications relating to functionality and performance of the described IC product.
Production	In production	The Datasheet contains specifications relating to functionality and performance of the described IC product which are supported by testing during development and production.

## Contact Details

**RediSem Ltd.**  
301-302 IC Development Centre  
No 6 Science Park West Avenue  
Hong Kong Science & Technology Park  
Shatin, New Territories  
Hong Kong

Tel. +852 2607 4141  
Fax. +852 2607 4140  
Email: [info@redisem.com](mailto:info@redisem.com)  
Web: [www.redisem.com](http://www.redisem.com)

## Disclaimer

The product information provided herein is believed to be accurate and is provided on an “as is” basis. RediSem Ltd assumes no responsibility or liability for the direct or indirect consequences of use of the information in respect of any infringement of patents or other rights of third parties. RediSem Ltd does not grant any licence under its patent or intellectual property rights or the rights of other parties.

Any application circuits described herein are for illustrative purposes only. Specifications are subject to change without notice. In respect of any application of the product described herein RediSem Ltd expressly disclaims all warranties of any kind, whether express or implied, including, but not limited to, the implied warranties of merchantability, fitness for a particular purpose and non-infringement of third party rights. No advice or information, whether oral or written, obtained from RediSem Ltd shall create any warranty of any kind. RediSem Ltd shall not be liable for any direct, indirect, incidental, special, consequential or exemplary damages, howsoever caused including but not limited to, damages for loss of profits, goodwill, use, data or other intangible losses.

The products and circuits described herein are subject to the usage conditions and end application exclusions as outlined in RediSem Ltd Terms and Conditions of Sale.

RediSem Ltd reserves the right to change specifications without notice. To obtain the most current product information available visit [www.redisem.com](http://www.redisem.com) or contact us at the address shown above.