

Dimming LED Controller

Features

- Advanced Resonant Controller IC for high efficiency LED drivers
- DIM input for linear dimming down to 10% load
- Optimized for 2-stage PFC and resonant LED drivers. RED2821 works with any APFC controller IC.
- +/-5% Primary Side Regulation of LED current and voltage with no Flicker
- 50% duty cycle, variable frequency control of resonant half-bridge
- Protection modes:
 - Short-circuit
 - No-Load
 - Internal Over-temperature
- No flicker - zero output current ripple



Small SO8 package

Applications

- Two stage linearly dimmable LED drivers without flicker
- Universal mains input LED drivers
- CC LED drivers up to 200W

Order code

Part Number	Package	Packaging
RED2821AD-TR13	SO8	Tape and reel

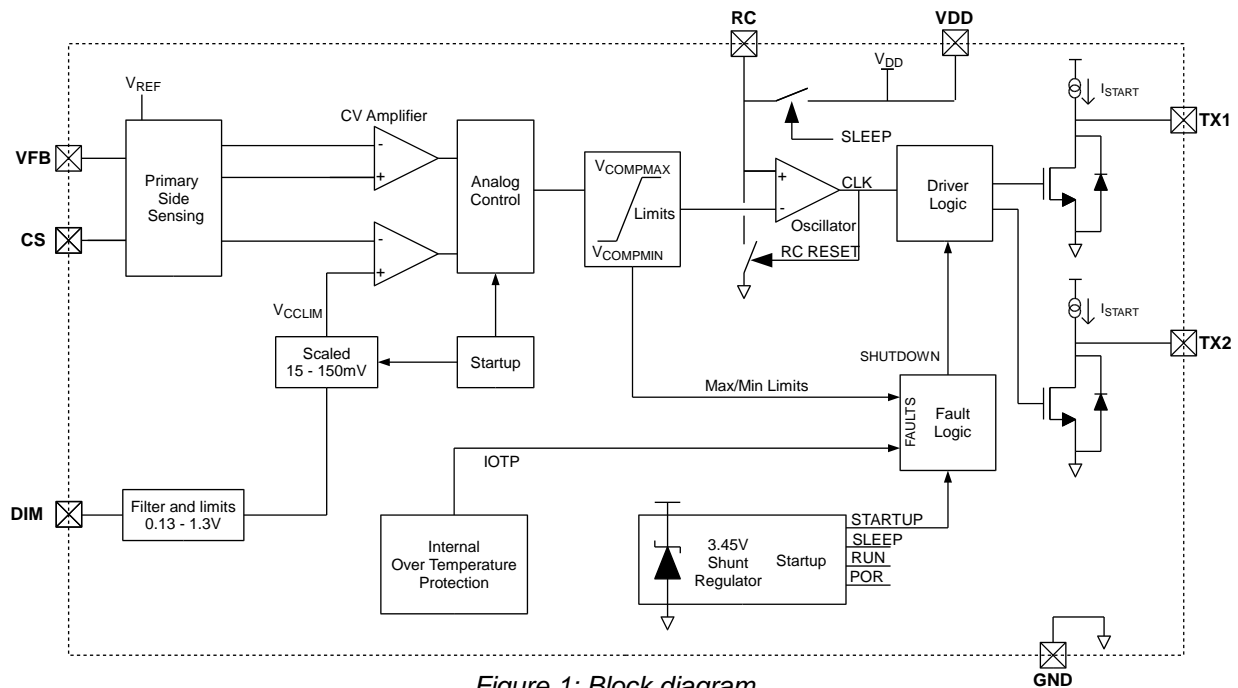

Figure 1: Block diagram

Device Pins

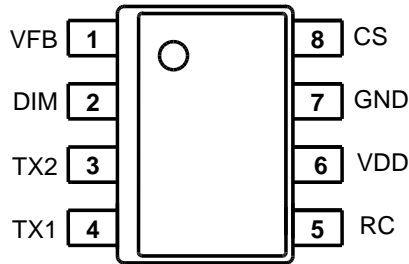

Figure 2: SO8 pin connections (top view)

Pin Functions

Pin #	Name	Function
1	VFB	PSR Feedback input for output voltage regulation. Connect to primary sense winding.
2	DIM	Output current varies linearly from 10% output when $V_{DIM} \leq 130\text{mV}$ up to 100% output when $V_{DIM} > 1.3\text{V}$. The pin can also be used as a high temperature power limiting pin with an NTC or for soft starting.
3	TX2	Output to control transformer.
4	TX1	Output to control transformer.
5	RC	External RC network sets the minimum [full power] switching frequency.
6	VDD	IC Power Supply pin – nominally 3.45V
7	GND	Chip ground.
8	CS	PSR Current Sense input provides output current regulation and cycle-by-cycle over-current protection. The CS pin is connected to the half-bridge current sense resistor.

Typical Application

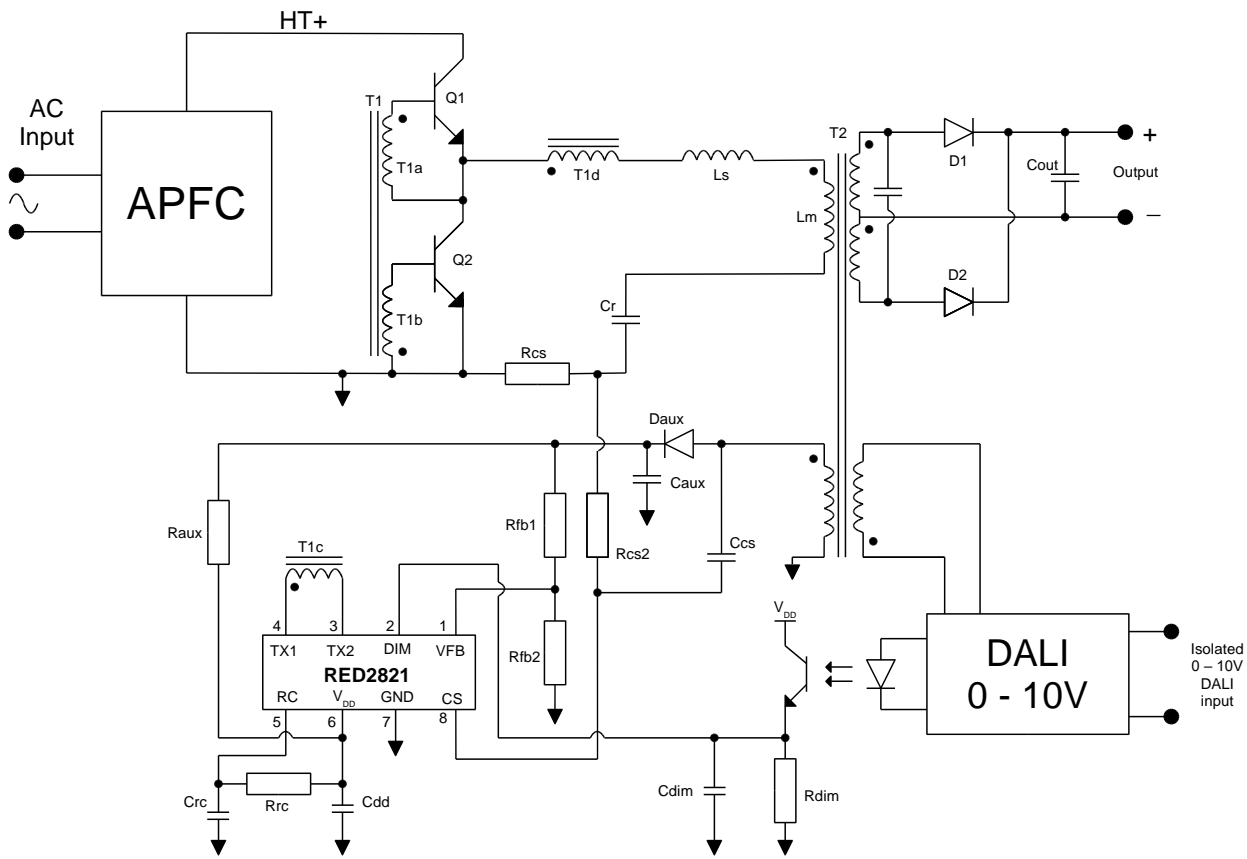

Figure 3: Typical Application : 2-stage LED driver with RED2821 LCC PSR controller and isolated DALI / 0-10V dimming input

Features

RED2821 is an advanced CMOS control IC for resonant converters. The RED2821 Primary Side Regulation (PSR) control scheme accurately controls the LED current and removes the need for secondary side opto-coupler feedback, reducing cost and complexity.

RED2821 uses the CSOC (Controlled Self-Oscillating Converter) scheme to drive two low-cost bipolar transistors in a half-bridge configuration. RED2821 is optimized to work alongside most APFC controllers.

Please contact RediSem for application design information for LED drivers with passive or active PFC.

Accurate Primary Side Regulation

The RED2821 PSR scheme regulates the LED drive current by modulating the converter frequency. Primary side current control enables +/-5% LED current regulation. With the LED disconnected, the RED2821 controls the maximum output voltage and enters fault-mode

operation to keep the output voltage from rising and to keep the power consumption low.

Linear Dimming

RediSem's patented dimming method allows accurate primary side controlled linear dimming. This means that the dimming circuit, whether ZigBee / Bluetooth / DALI or 0 – 10V can be easily interfaced with the RED2821 whilst remaining completely isolated from the LED.

Protection Features

The IC is able to detect a number of faults that cause the IC to enter a fault mode:

- Output Open circuit (no LED connected)
- Output short circuit
- Over-temperature fault

During these fault conditions, the IC will continually attempt to re-start. Between each re-start attempt there will be 8 dummy re-starts when the IC re-starts while the converter is off.

If the output is short-circuit, the auxiliary power to the IC fails and the IC shuts down. The IC detects this and when it next re-starts, it does so at half output current. It continues to shut down and re-start until the short has been removed. If the fault is removed, the IC will automatically return to full output current.

The IC also has an instantaneous cycle-by-cycle over-current protection (OCP) level that will terminate any cycle instantaneously should the current exceed a pre-set level.

Over-temperature Protection & Shutdown

An internal over-temperature protection shuts down the controller if the IC temperature exceeds 125°C. The IC will restart the converter when the IC temperature drops by 15°C.

Automatic Dead-Time Control

An important feature of the Controlled Self Oscillating Converter is that the dead-time is controlled naturally. Unlike MOSFET half-bridge converters, it is not necessary to program the dead-time on RED2821. The bipolar switching transistors are turned on correctly through the self-oscillation of the converter and turned off by RED2821. This greatly simplifies the design process and improves the robustness of the resonant converter.

Capacitive Mode Protection

RED2821 includes a capacitive mode protection feature which prevents the converter from entering capacitive switching mode on a cycle-by-cycle basis by limiting the minimum frequency. This always ensures the Controlled Self Oscillating Converter continues to oscillate correctly.

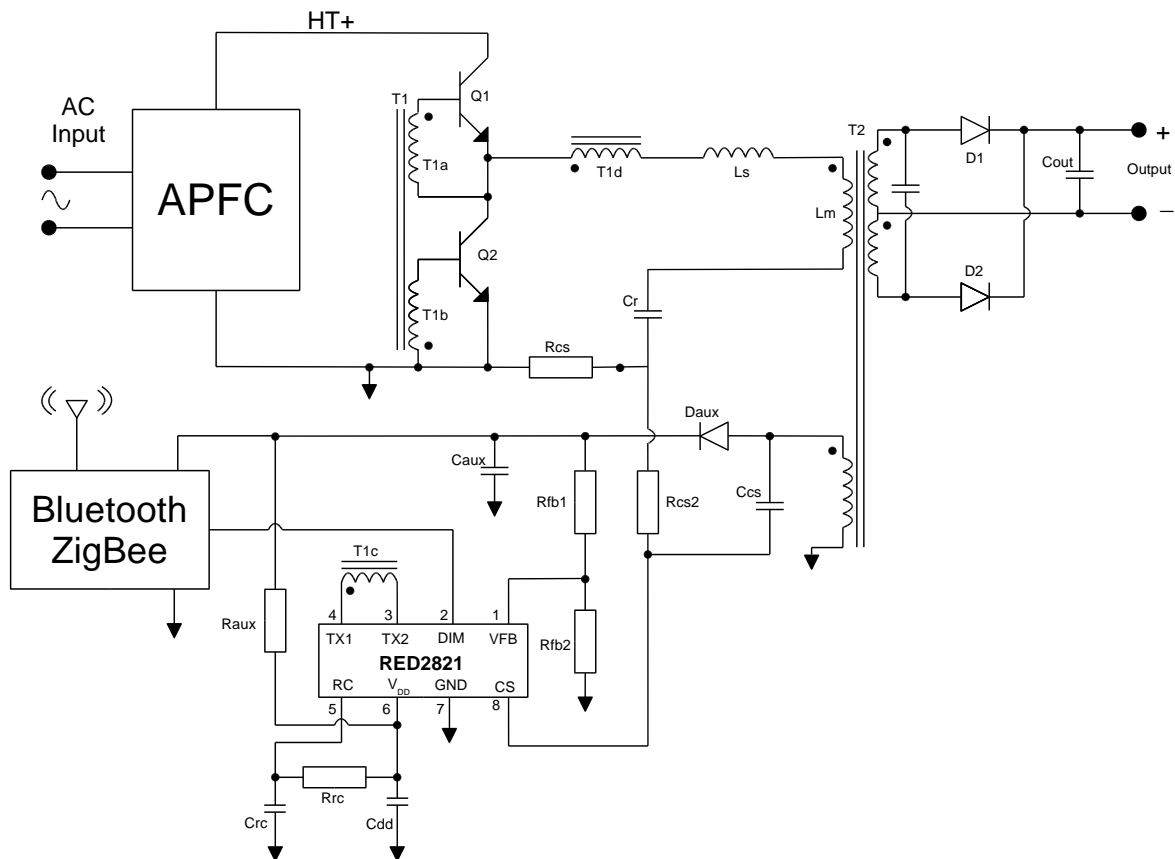

Figure 4: Application showing wireless primary side control

IC Operation

Startup, Shutdown and re-start

Figure 5 shows typical startup waveforms for RED2821. In SLEEP mode the I_{DD} current is approximately 8 μ A ($I_{DD\text{SLEEP}}$). Once VDD reaches 3.7V ($V_{DD\text{START}}$) the IC enters STARTUP mode. During the initial period of approximately 40ms (2048 cycles) VDD is allowed to drop to 2.4V or rise to 3.6V. This gives time for the application to pull up the output voltage. After this the IC

enters RUN mode when the controlled Zener clamp inside the IC regulates the VDD voltage to 3.45V ($V_{DD\text{REG}}$). The IC current is now approximately 0.7mA ($I_{DD\text{REG}}$) plus any excess current required to clamp VDD to 3.45V. If VDD falls below 3.45V ($V_{DD\text{REG}}$) the Zener clamp turns off and I_{DD} reduces to 0.7mA ($I_{DD\text{REG}}$) only. If VDD falls below 3.0V ($V_{DD\text{SLEEP}}$), the IC enters SLEEP mode. In this condition I_{DD} reduces to 8 μ A ($I_{DD\text{SLEEP}}$).

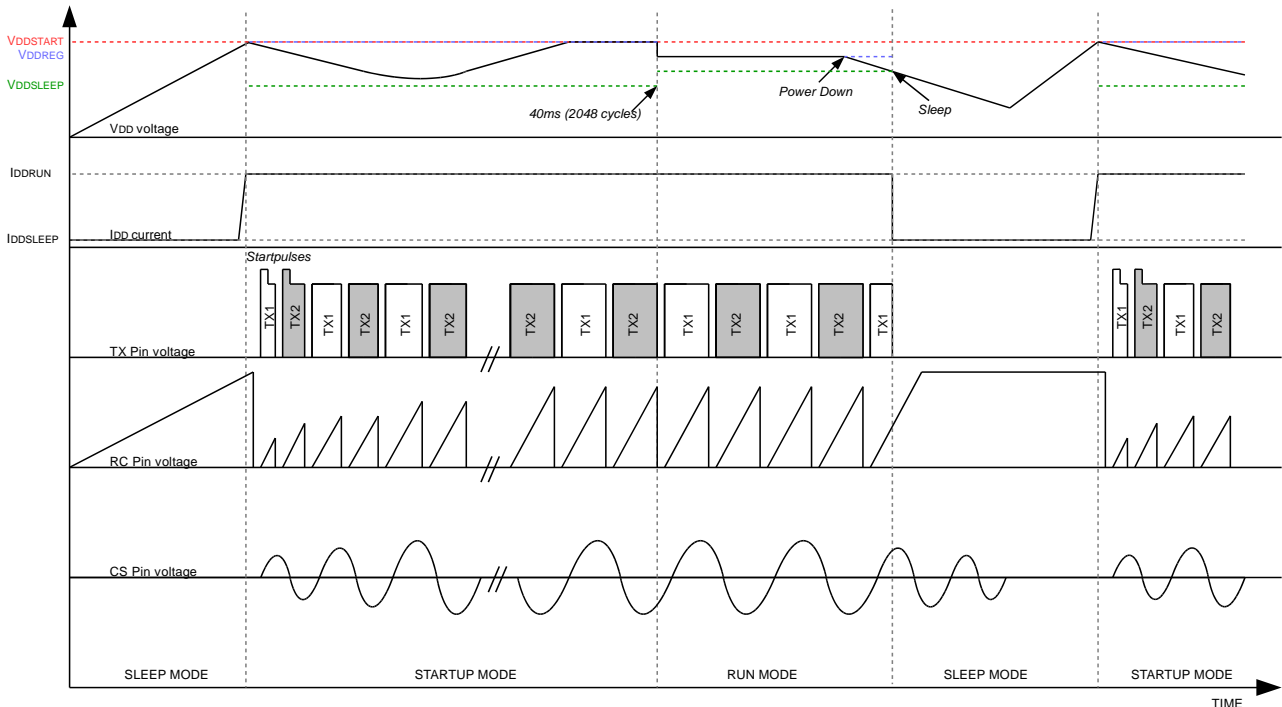

Figure 5: IC Start-up waveforms

Output stage

A diagram of the output stage can be seen in Figure 6. To start the converter oscillating the RED2821 issues start pulses through the TX pins during the first two cycles. These start pulses are 800ns long ($t_{TX\text{START}}$) and provide 14mA ($I_{TX\text{START}}$) current pulses from both TX1 and TX2 pins. After this the converter self-oscillates and no longer needs start pulses to maintain oscillation. A low

on-state NMOS transistor is used to turn the bipolar transistors off. It is controlled by the oscillator off-time. The NMOS device is turned to pull TX pin low, which switches off the corresponding bipolar transistor in the power converter half-bridge.

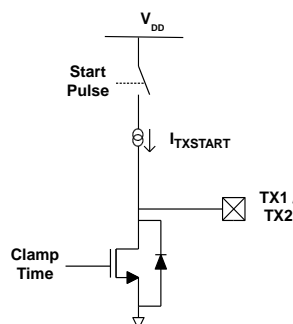

Figure 6: Output Stage

Primary Side Regulation (PSR)

The converter's output current and voltage are estimated by the RED2821 PSR scheme. Inside the IC there are two separate control loops that control the converter output current (in CC mode) and voltage (in CV mode). The RED2821 regulates the output current and voltage by controlling the frequency. An Oscillator Control Voltage is fed into the oscillator comparator to give the desired operating frequency. V_{CCREG} is

derived from the DIM pin input and provides a reference for the average current sense amplifier. This voltage varies proportionally to the DIM pin voltage. Figure 7 shows how the current and voltage error amplifiers with their compensation networks are configured for a primary regulated resonant converter.

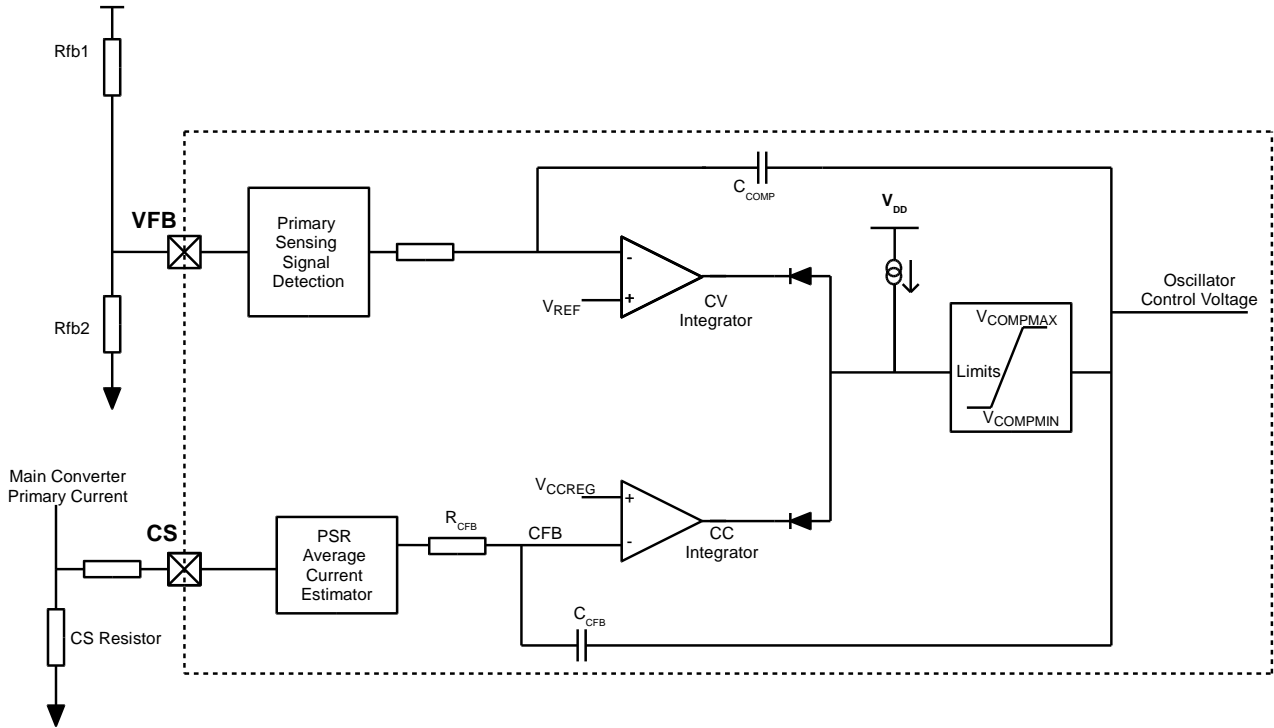

Figure 7: Error Amplifier Circuits

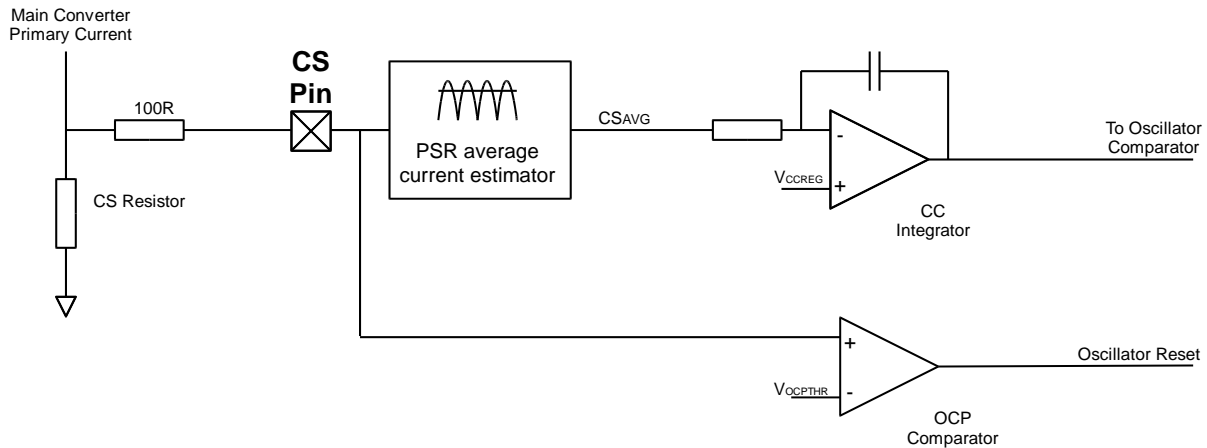

Figure 8: RED2821 Current protection and control circuits

PSR Current Control

Figure 8 shows the two current control methods used in the converter:

1. constant current (CC) regulation;
2. an instantaneous peak current limit (OCP).

PSR Average current estimation

It can be seen in figure 8 that the signal from the CS pin is divided into two different paths. The bottom path provides peak instantaneous over-current protection (OCP) while the PSR Average Current estimation block provides the current regulation (CC) information. The voltage on the CS pin is an AC signal biased around GND. Inside the PSR block this signal is processed to provide a voltage proportional to the average converter output current.

Constant Current Regulation

The CC regulation circuit is shown in figure 8. CC operation is defined by an internally compensated control loop. This provides a system response time of approximately 150us in a typical application.

The average current regulation point, V_{CCREG} is pre-set to a maximum of 150mV and a minimum of 15mV depending on the voltage of the DIM pin. When the IC is first turned on, the DIM pin is ignored and V_{CCREG} is set to 150mV until VFB reaches 500mV.

Over Current Protection

Over-Current Protection (OCP) is an instantaneous termination of the current oscillator

cycle and the transistor on-time. When a peak voltage occurs that exceeds the OCP threshold V_{OCP_THR} (+/- 500mV) the OCP comparator terminates the current oscillator on-time cycle. The oscillator is reset and the off-time begins resulting in the bipolar transistors turning off and the half-bridge commutating. This is repeated in subsequent cycles whenever the CS voltage exceeds an OCP threshold. Note that in a correctly designed converter it should not be possible to trip OCP in normal operation.

PSR Voltage Control

RED2821 features an internally compensated CV control loop to control the maximum LED converter output voltage. The VFB input senses the output voltage from an auxiliary winding on the primary side of the transformer. This signal is conditioned in the PSR block and compared to a voltage reference of 1.2V (V_{REF}) inside the IC.

In CV mode the VFB pin is regulated to V_{REF} by adjusting the internal control voltage and therefore the converter operating frequency. If the VFB pin voltage exceeds V_{REF} , RED2821 will enter shutdown.

In a constant current LED application the VFB voltage will normally be below the 1.2V regulation point V_{REF} as the CC control loop determines the control voltage. If the LED voltage is too high, or the LED becomes disconnected, the CC loop is not in control and the VFB voltage will exceed 1.2V V_{REF} control voltage. At that point RED2821 will shut down and enter fault mode, re-starting regularly to check if the fault has been removed.

Oscillator

The oscillator (see Figure 9) controls the period of a converter half-cycle. Internal to the IC is an oscillator comparator that compares the voltage on the RC pin to a control voltage. The RC pin has a saw tooth type waveform and the control voltage is inversely proportional to the required frequency.

The control voltage can vary from 0.3V to 2.35V, resulting in a maximum to minimum frequency ratio of nearly 7x for any input voltage.

The timing capacitor C_{RC} may be chosen within the range 100 – 1000 pF. The recommended type is a 5% COG/NPO capacitor.

The oscillator timing resistor R_{RC} should be connected to the IC's V_{DD} pin. The value of R_{RC} may be calculated using following equation:

$$F_{MIN} = \frac{1}{2 \times \left(0.8 \times 10^{-6} - R_{RC} \times C_{RC} \times \ln \left(1 - \frac{2.35}{3.45} \right) \right)}$$

This equation gives the lowest possible operating frequency of the converter.

When designing with the RED2821, ensure that at the converter resonant frequency the peak RC voltage is around 2V.

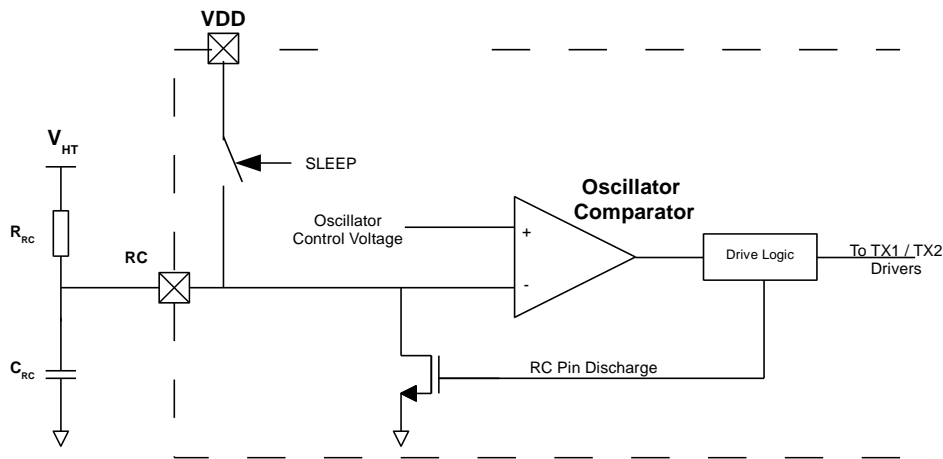

Figure 9: Oscillator circuit

DIM pin

RED2821 features a dimming input that controls the average rectified voltage on the CS pin. A signal of $\leq 130\text{mV}$ on the DIM pin will therefore result in the minimum dim level (10% output) and a signal of $\geq 1.3\text{V}$ will result in a maximum dim level (i.e. LED fully on).

When the IC is first turned on, the DIM pin is ignored until the VFB pin reaches 0.5V . For $V_{\text{FB}} < 0.5\text{V}$, the IC controls for maximum output current. This is so that the output capacitance C_{OUT} is charged quickly which will also result in

C_{AUX} being charged quickly in order to power the IC (referring to figure 3). The DIM pin also has filtering with a time-constant of greater than 1ms to remove LED flicker. This time-constant is much faster at startup to ensure that the IC adopts the correct DIM level before the LED turns on.

A graph showing the relationship between the LED driver output current and the DIM pin voltage is given in figure 11. The IC will control the average rectified voltage on the CS pin.

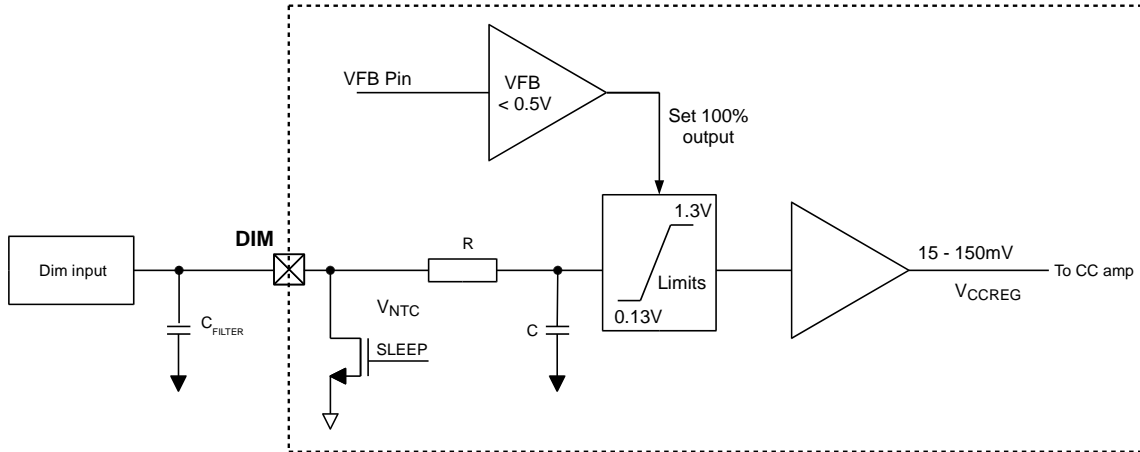

Figure 10: RED2821 DIM pin circuit

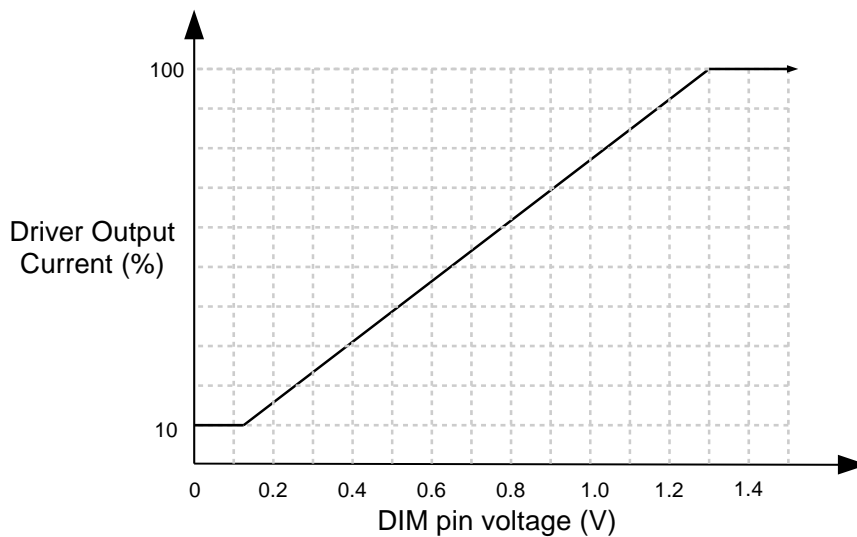

Figure 11: DIM pin voltage vs output current



ABSOLUTE MAXIMUM RATINGS

CAUTION: Permanent damage may result if a device is subjected to operating conditions at or in excess of absolute maximum ratings.

Parameter	Symbol	Condition	Min	Max	Unit
Supply voltage	V _{DD}	SLEEP mode: self-limited by IC start-up (V _{DDSTART})	-0.5	4.5	V
Supply voltage	V _{DD}	RUN mode: Self-limited by internal shunt regulator	-0.5	4.0	V
Supply current	I _{DD}		0	10	mA
Input/output voltages	V _{IO}		-0.5	V _{DD} + 0.5	V
Input/output currents	I _{IO}		-10	10	mA
Junction temperature	T _J	T _{J_MAX} limited by OTP (T _{OTPS_MAX})	-25	+135	°C
Storage temperature	T _P		-25	+125	°C
Lead temperature	T _L	Soldering, 10 s		260	°C
ESD withstand		Human body model, JESD22-A114		2	kV
		Capacitive Discharge Model		500	V

NORMAL OPERATING CONDITIONS

Unless otherwise stated, electrical characteristics are defined over the range of normal operating conditions. Functionality and performance is not defined when a device is subjected to conditions outside this range and device reliability may be compromised.

Parameter	Symbol	Condition	Min	Typ	Max	Unit
Minimum supply current	I _{DDMIN}		0.8	1.0	1.2	mA
Junction temperature	T _J		-25	25	125	°C

ELECTRICAL CHARACTERISTICS

Unless otherwise stated:

- Min and Max electrical characteristics apply over normal operating conditions.
- Typical electrical characteristics apply at T_J = T_{J(TYP)} and I_{DD} = I_{DDREG(TYP)}.
- The chip is operating in RUN mode.
- Voltages are specified relative to the GND pin.

VDD Pin

Parameter	Symbol	Condition	Min	Typ	Max	Unit
Supply voltage	V _{DDSTART}	Enter RUN mode from SLEEP	3.2	3.7	4.2	V
	V _{DDREG}	I _{DD} < I _{DDSHUNT}	3.3	3.45	3.6	V
	V _{DDSLEEP}	To enter SLEEP mode	2.7	2.9	3.1	V
Supply current	I _{DDREG}	In RUN mode, V _{DD} < V _{DDREG}		0.7	0.8	mA
	I _{DDSLEEP}	In SLEEP mode		8	12	µA
	I _{DDSHUNT}	VDD shunt regulator max current			8	mA



RED2821 Dimming LED Controller

VFB Pin

Parameter	Symbol	Condition	Min	Typ	Max	Unit
VFB threshold voltage	V _{REF}	T _J = 0°C to 85°C, V _{DD} =3.45V	1.15	1.20	1.25	V
VFB Standby threshold	V _{FBSTBY} *			0.5		V

CS Pin

Parameter	Symbol	Condition	Min	Typ	Max	Unit
Maximum Constant current regulation	V _{CCREG(MAX)}	DC CS signal. T _J = 0°C to 85°C DIM ≤ V _{DIMMIN}	146	150	154	mV
Minimum Constant current regulation	V _{CCREG(MIN)}	DC CS signal. T _J = 0°C to 85°C DIM ≥ V _{DIMMAX}		15		mV
Instantaneous over-current protection threshold	V _{OCPTHR}			500		mV

RC Pin

Parameter	Symbol	Condition	Min	Typ	Max	Unit
External capacitor range	C _{RC}		100		1000	pF
Oscillator Frequency Variation	ΔF _{RC} /F _{RC} *	T _J = 0°C to 85°C, C _{RC} =330pF, V _{DD} =3.45V, min frequency			5	%
Oscillator reset time	T _{RCSRST}			0.7		μs

DIM Pin

Parameter	Symbol	Condition	Min	Typ	Max	Unit
Maximum output Dim Pin Voltage	V _{DIMMAX}			1.3		V
Minimum output Dim Pin Voltage	V _{DIMMIN}	VFB > 0.5V		130		mV

TX1, TX2 Pins

Parameter	Symbol	Condition	Min	Typ	Max	Unit
On-state resistance	R _{TXON}			1.0	1.5	Ω
TX pin clamp current	I _{TXCLAMP} *	TX pin frequency >30kHz			800	mA
Start-pulse output current	I _{TXSTART}	TX pin voltage 2V		28		mA
Start-pulse width	T _{TXSTART}			800		ns

Over-Temperature Protection (OTP)*

Parameter	Symbol	Condition	Min	Typ	Max	Unit
Over-Temperature Protection threshold	T _{OTPS}	At silicon junction	115	125	135	°C
Over-Temperature Protection reset hysteresis	T _{OTP_HYS}	At silicon junction		15		°C

*: not tested in production

PACKAGE INFORMATION

Package Dimensions

SO8N package dimensions are shown below. All units are in mm.

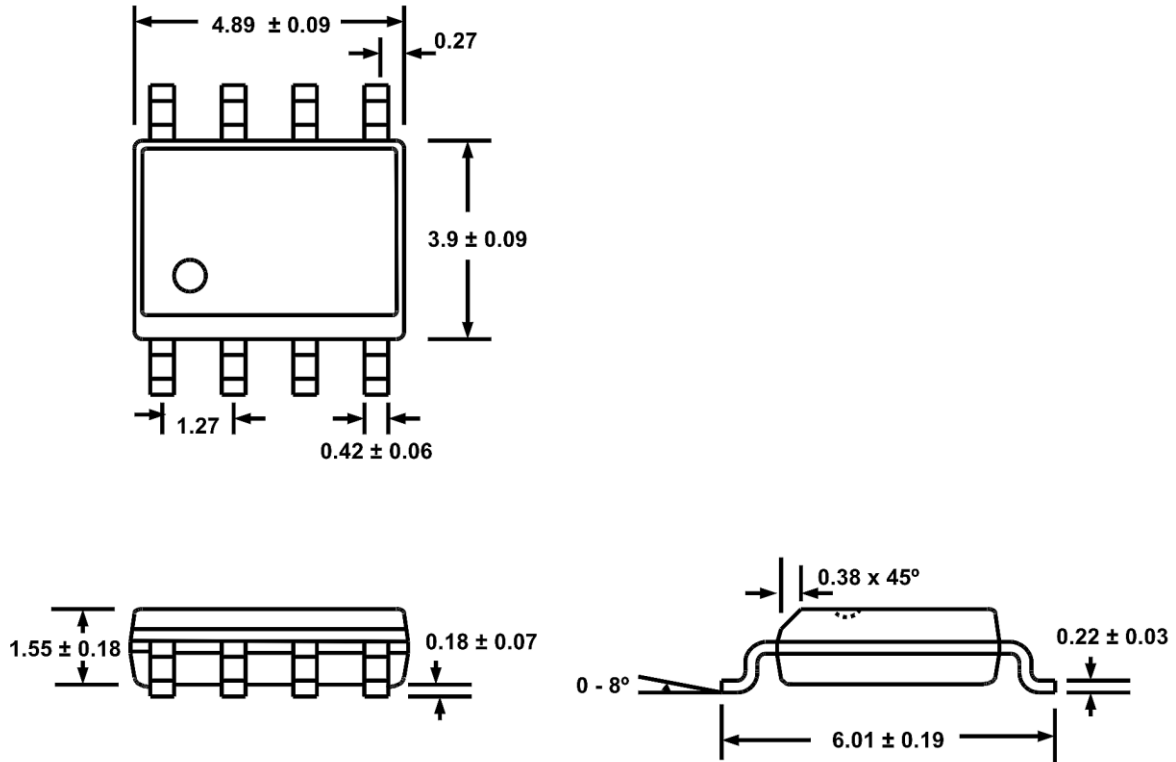

Available packages

Package type	Part number	Moisture Sensitivity Level (MSL)	Packaging	Thermal Resistances		
				Junction - Lead	θ_{JL}	30°C/W
SO8	RED2821AD-TR13	3 (JEDEC J-STD-020)	Tape and reel 2500pcs/13" reel	Junction - Ambient	θ_{JA}	150°C/W

Package Marking

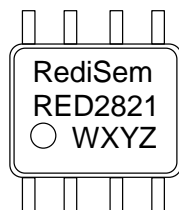

SO8 top-side marking for RED2821

RED2821= Part Number

WXYZ= Lot Code, e.g. AAAA, AAAB



Status

The status of this Datasheet is shown in the footer.

Datasheet Status	Product Status	Definition
Preview	In development	The Datasheet contains target specifications relating to design and development of the described IC product.
Preliminary	In qualification	The Datasheet contains preliminary specifications relating to functionality and performance of the described IC product.
Production	In production	The Datasheet contains specifications relating to functionality and performance of the described IC product which are supported by testing during development and production.

Contact Details

RediSem Ltd.
301-302 IC Development Centre
No 6 Science Park West Avenue
Hong Kong Science & Technology Park
Shatin, New Territories
Hong Kong

Tel. +852 2607 4141
Fax. +852 2607 4140
Email: info@redisem.com
Web: www.redisem.com

Disclaimer

The product information provided herein is believed to be accurate and is provided on an “as is” basis. RediSem Ltd assumes no responsibility or liability for the direct or indirect consequences of use of the information in respect of any infringement of patents or other rights of third parties. RediSem Ltd does not grant any licence under its patent or intellectual property rights or the rights of other parties.

Any application circuits described herein are for illustrative purposes only. Specifications are subject to change without notice. In respect of any application of the product described herein RediSem Ltd expressly disclaims all warranties of any kind, whether express or implied, including, but not limited to, the implied warranties of merchantability, fitness for a particular purpose and non-infringement of third party rights. No advice or information, whether oral or written, obtained from RediSem Ltd shall create any warranty of any kind. RediSem Ltd shall not be liable for any direct, indirect, incidental, special, consequential or exemplary damages, howsoever caused including but not limited to, damages for loss of profits, goodwill, use, data or other intangible losses.

The products and circuits described herein are subject to the usage conditions and end application exclusions as outlined in RediSem Ltd Terms and Conditions of Sale.

RediSem Ltd reserves the right to change specifications without notice. To obtain the most current product information available visit www.redisem.com or contact us at the address shown above.