

Features

- Advanced Controller IC for LLC converters with bipolar transistors
- 50% duty cycle, variable frequency control of resonant half-bridge
- Regulated output voltage & current
- Automatic dead-time control
- Capacitive Mode protection
- Triple-mode over-current protection:
 - Programmable CC mode,
 - Cycle-by-cycle overcurrent protection
 - Hiccup overload protection
- Over-temperature protection
- Small SO8 IC package



SO8

Applications

- High Efficiency Adapters 5 - 60W
- Low EMI power supplies
- High surge capability power supplies

Order code

Part number	Package	Packaging
RED1501AD-TR13	SO8	Tape and reel

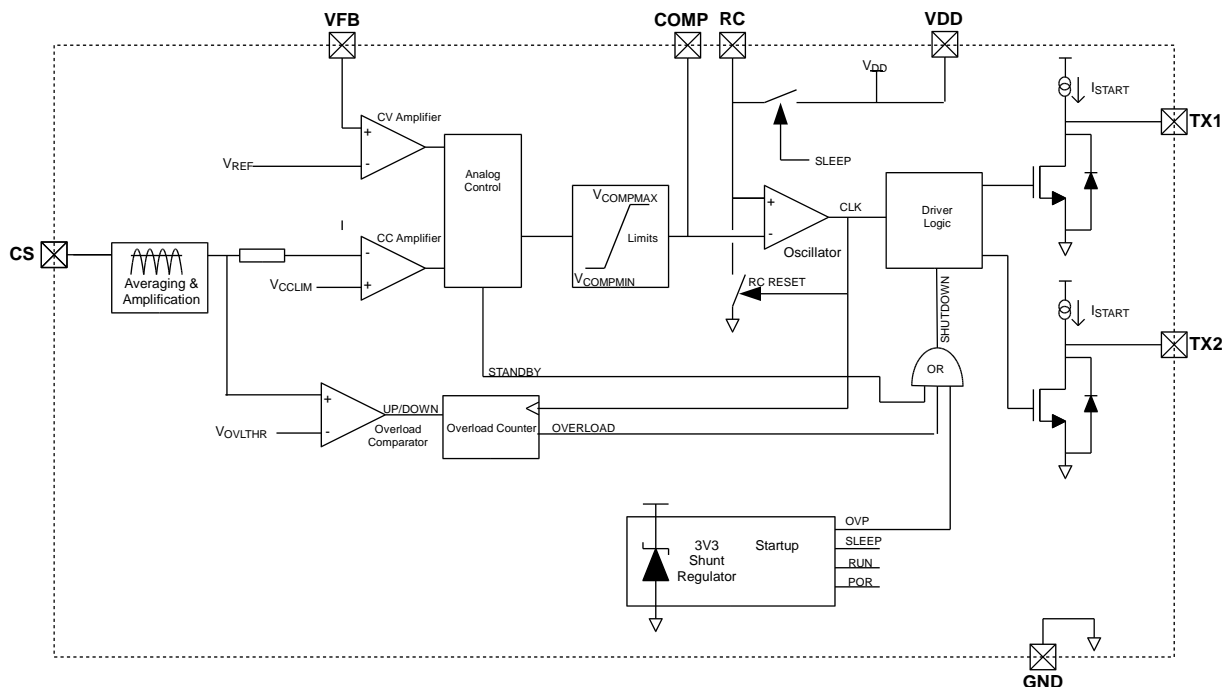

Figure 1: RED1501 Block diagram

Device Pins

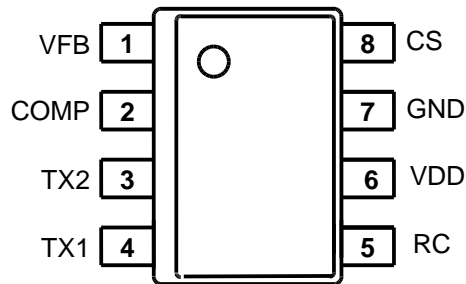

Figure 2: S08 pin connections (top view)

Pin Functions

Pin #	Name	Function
1	VFB	Voltage feedback input, normally connected to an opto-coupler providing secondary voltage regulation.
2	COMP	Buffered output of the control amplifiers. A loop compensation network connected between this pin and the VFB input defines CV mode loop response.
3	TX2	Output to control transformer.
4	TX1	Output to control transformer.
5	RC	External RC network sets the minimum [full power] switching frequency.
6	VDD	IC Power Supply pin . Decouple with a 470nF ceramic capacitor close to the pin.
7	GND	Chip ground.
8	CS	Current sense input is normally connected to the half-bridge current sense resistor and provides output current limiting, cycle-by-cycle overcurrent protection and delayed overload protection.

Typical Application

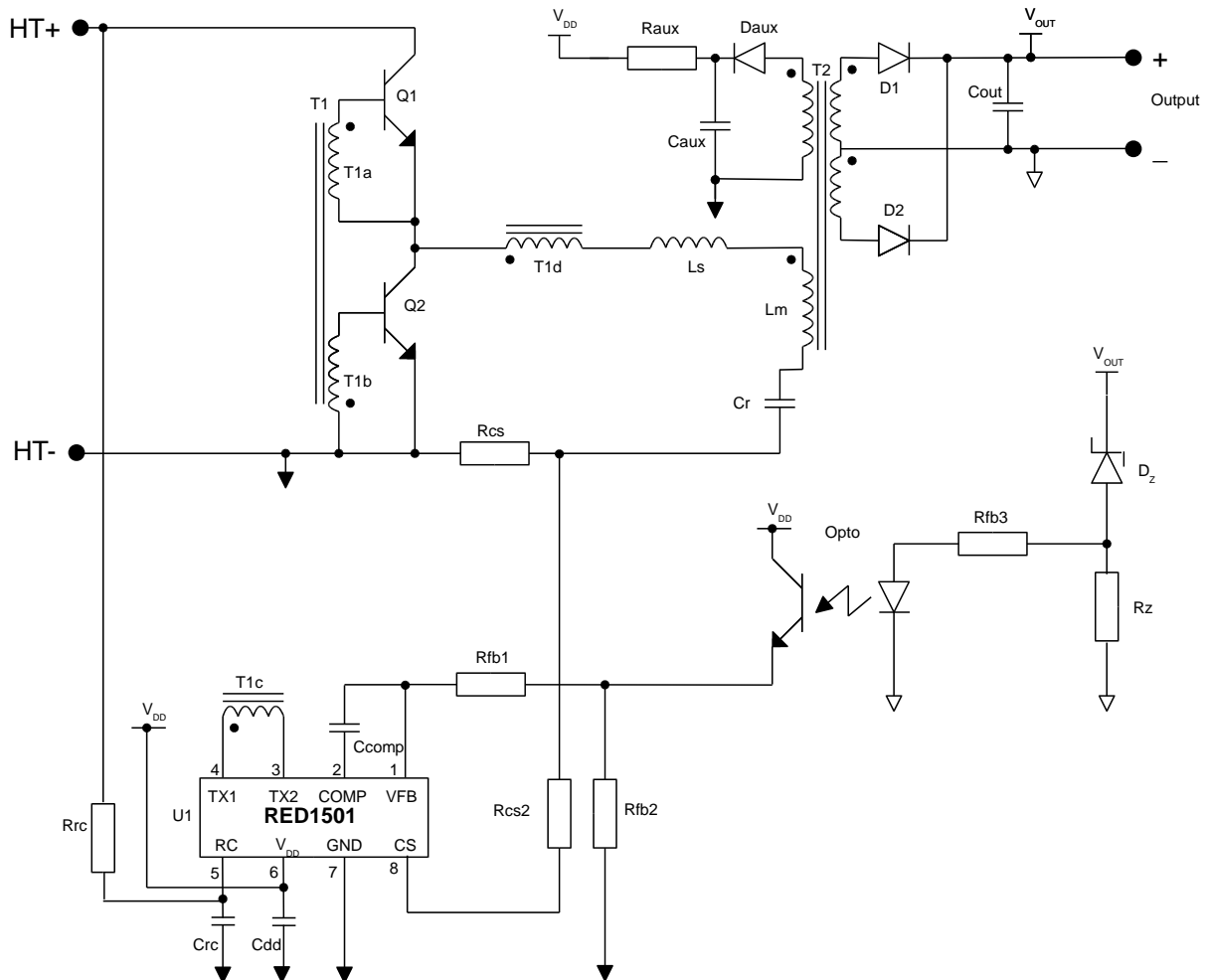

Figure 3: Typical Application Schematic using RED1501

Application Features

The RED1501 is a controller specifically intended for resonant half-bridge topology. Output voltage and current regulation are obtained by modulating the frequency.

RED1501 uses the CSOC (Controlled Self-Oscillating Converter) scheme to drive two low-cost bipolar transistors in a half-bridge configuration. RED1501 based LLC converters are able to achieve much higher efficiencies than similar flyback designs.

The IC enables the designer to set the operating frequency range of the converter by means of an externally programmable oscillator.

The IC enters a controlled burst-mode operation at light load, minimising the converter's input

power consumption. The point at which the IC enters burst mode is pre-set to a value derived from the average primary-side current.

A current sense input, CS, provides constant current (CC) operation by frequency shift, long-term overload (OVL) protection by delayed shutdown with automatic restart and instantaneous cycle-by-cycle overcurrent protection (OCP). The CC and OVL threshold levels are pre-set to values derived from the average primary-side current. The OCP threshold is pre-set to a value derived from the peak primary-side current. An over-temperature protection (OTP) feature shuts down the controller if the IC temperature exceeds the pre-set threshold.

A Feedback Protection Feature (FBP) shuts down the controller if the feedback signal is lost.

design process and improves the robustness of the LLC converter.

Automatic Dead-Time Control

Unlike the standard MOSFET converter solutions, it is not necessary to program the dead-time on the RED1501. An important feature of the self-oscillating circuit is that the dead-time is controlled naturally. The switching transistors are turned on at the optimum moment by the self-oscillation of the converter and turned off by the RED1501. This advantage greatly eases the

Inherent Capacitive Mode Protection

The self-oscillating converter is inherently unable to sustain oscillation in capacitive switching mode and is therefore simpler to design than comparable MOSFET-based solutions. The RED1501 includes a capacitive mode protection feature which prevents the converter from entering capacitive switching mode on a cycle-by-cycle basis by limiting the minimum frequency.

IC Operation

Startup, Shutdown and re-start

Figure 4 shows typical waveforms for the RED1501 when it starts. In SLEEP mode the IC is off and I_{DD} is approximately 8 μ A ($I_{DD\text{SLEEP}}$). Once VDD reaches 3.6V ($V_{DD\text{START}}$) the IC goes into RUN mode. The controlled Zener clamp inside the IC turns on and regulates the VDD voltage down to 3.4V ($V_{DD\text{REG}}$). The IC current is

approximately 0.7 mA ($I_{DD\text{REG}}$) plus any excess current that is required to clamp VDD to 3.4V.

If VDD falls below $V_{DD\text{REG}}$ the Zener clamp turns off and I_{DD} reduces to 0.7 mA ($I_{DD\text{REG}}$) only. If VDD falls more than 0.5V ($\Delta V_{DD\text{SA}}$) below $V_{DD\text{REG}}$, the IC tries to keep itself alive by entering RUN mode and issuing start pulses.

If VDD falls by 1V ($\Delta V_{DD\text{SLEEP}}$) below $V_{DD\text{REG}}$, the IC enters SLEEP mode. In this condition I_{DD} reduces to 8 μ A ($I_{DD\text{SLEEP}}$).

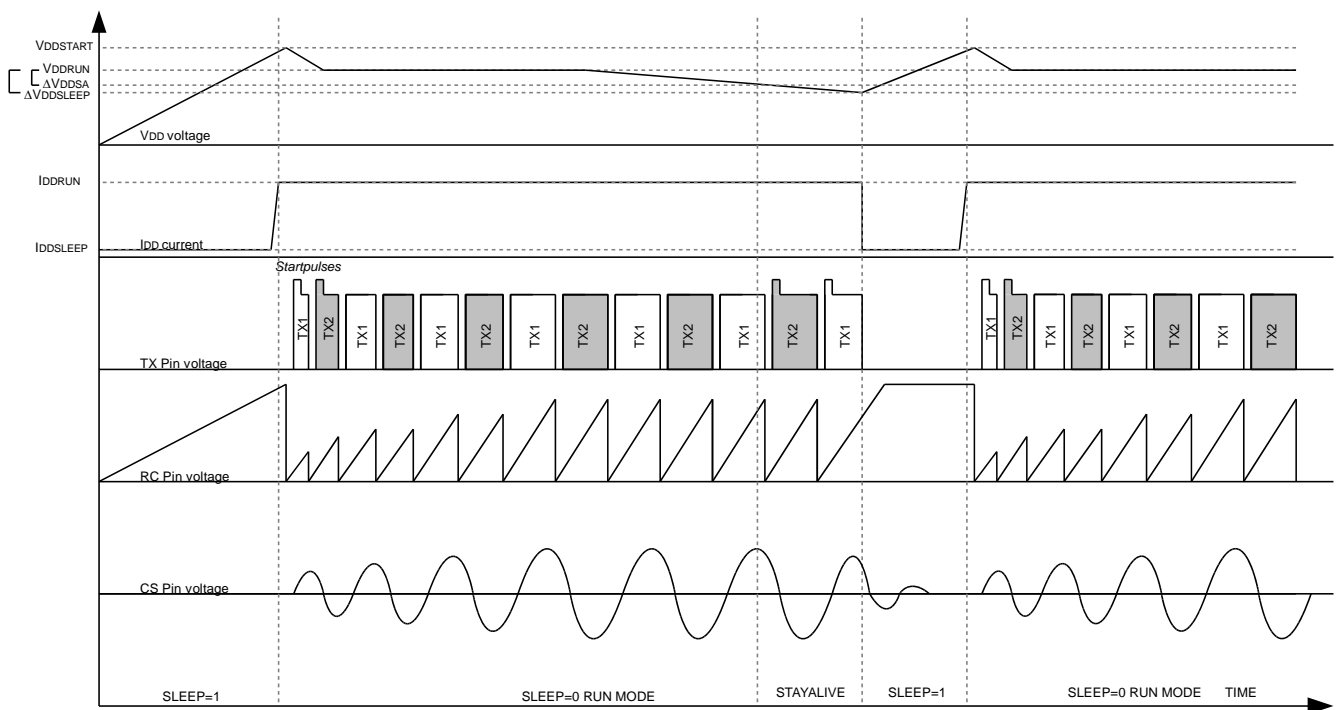

Figure 4: IC Startup waveforms

Start pulses

The RED1501 provides start pulses to force the converter into oscillation. To start the converter oscillating the TX pins issue a start pulse during each of the first four consecutive on-times. These start pulses are

500ns long ($t_{TXSTART}$), and provide 8mA ($I_{TXSTART}$) current pulses from both TX1 and TX2 pins. After this the converter continues to self-oscillate and no longer needs start pulses to maintain oscillation.

Output stage

A diagram of the output stage can be seen in Figure 5. The large NMOS transistor is controlled by the oscillator off-time. It is turned on when the TX pin is to be pulled low, in order to switch off the corresponding bipolar transistor in the power converter.

The drive stage includes an 8mA current source, which is turned on for the first four pulses when the IC is starting up the converter oscillation, e.g. at the start of a burst.

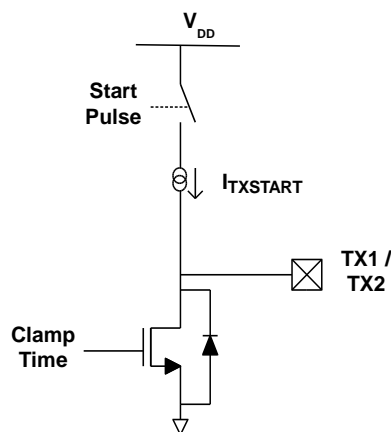

Figure 5: Drive Stage

Voltage and Current Regulation

The output voltage and current are regulated by the RED1501 IC and the external feedback loop. Inside the IC there are two separate control loops that control the converter output Voltage (in CV mode) and the output Current (in CC mode). The RED1501 regulates the output voltage and output current by controlling the frequency. A control

voltage (COMP) is fed into the oscillator to give the desired operating frequency. Figure 6 shows how the two error amplifiers and their compensation networks are configured for a typical application utilising primary voltage sensing.

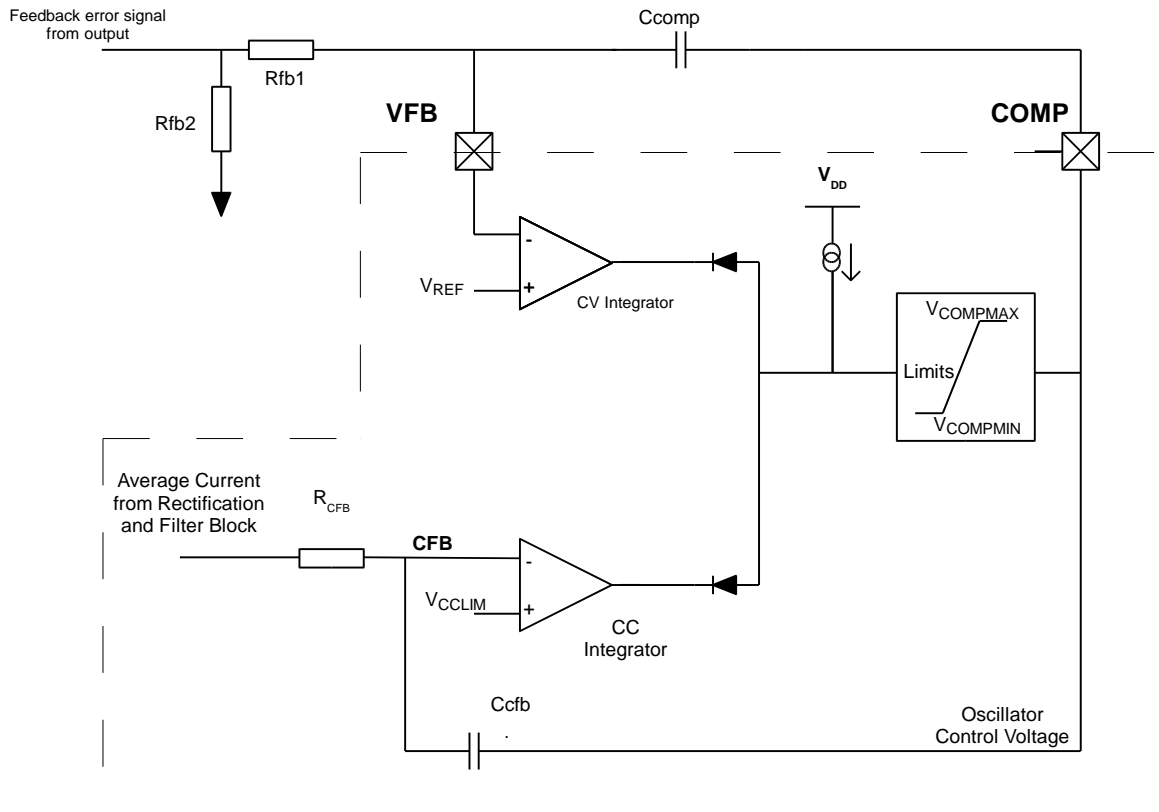

Figure 6: Error Amplifier Circuits

Voltage Compensation Loop

The feedback network between the COMP and VFB pins defines the loop gain and phase for the voltage control loop. In a system with primary sensing, this network could be configured to form an integrator with lead compensation and some

high-frequency noise suppression. The input receives an error signal fed back from the output of the power supply and compares this to a fixed voltage reference of 1.2V (V_{REF}) inside the IC.

Current Protection Methods

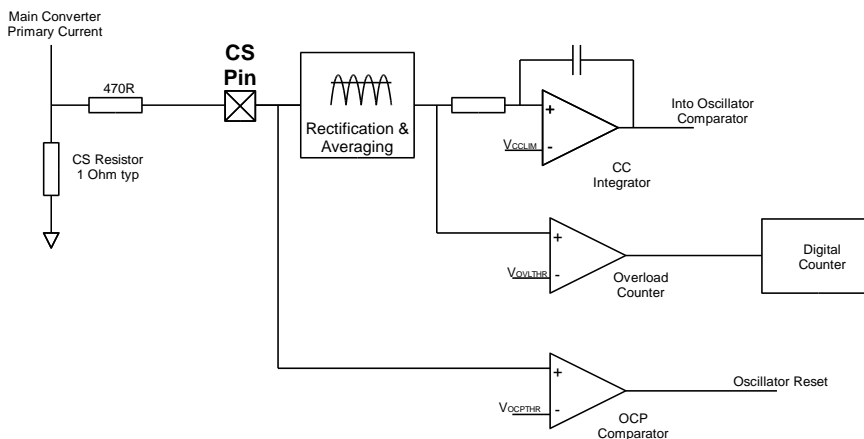

Figure 7: current protection circuits

Figure 7 shows the three current protection methods used in the converter:

1. a short-term constant current (CC) limit;
2. a long term current overload (OVL) shutdown;
3. an instantaneous peak current limit (OCP).

Current averaging Circuit

Shown in Figure 7, the signal from the CS pin is divided into two different paths. The bottom path provides peak instantaneous over-current protection (OCP) while the constant current limit (CC) and the average current overload (OVL) both use the averaged current signal. The voltage on the CS pin is an AC signal biased around GND. Inside the IC, the signal is first rectified and low-pass filtered. This filtered signal is proportional to the average primary current (and therefore the output current) of the converter.

Constant Current Limiting

The CC limiting circuit is shown in Figure 7. The CC operation is defined by an internal control loop, using an integrator with a time constant of approximately 100 μ s.

This provides a system response time of approximately 1ms in a typical SMPS application. The constant current limit, V_{CCCLIM} is pre-set to 150 mV, referred to the CS pin. This corresponds to 150% of nominal load.

Average current overload

The rectified average current is compared to a threshold level V_{OVLTHR} . A characteristic of the

LLC converter is that the magnetising current increases significantly as the switching frequency decreases, which happens when the line input voltage decreases. To compensate for this, the overload threshold voltage V_{OVLTHR} is dependent upon the COMP voltage. In a typical application, the COMP voltage will be approximately 1.8V when running resonantly at 120% load, giving $V_{OVLTHR}=120$ mV. The overload counter is a bi-directional counter that counts up when the converter output current exceeds the limit and counts down when the converter current is lower than the limit. Once the cumulative count of up's and down's equates to 8192, the IC goes into SLEEP mode and the converter shuts down.

After 32 dummy restart attempts, (typically 2 s) the converter will re-start again. The IC issues start pulses and the converter starts up as normal. If the overload persists, the converter will shut down again, but if the overload has been removed, the converter will continue operating normally.

Over Current Protection

Over-Current Protection (OCP) is an instantaneous termination of the transistor on-time. When a voltage greater than ± 400 mV (V_{OCPTHR}) is sensed on the CS pin the OCP comparator provides a pulse to the oscillator to terminate the current on-time. The oscillator cycle is terminated and the off-time begins. This is repeated in subsequent cycles whenever the CS voltage exceeds the threshold.

Oscillator

The oscillator (see Figure 8) controls the period of a half-cycle. Internal to the IC is a comparator that compares the voltage on the RC pin to the voltage on the COMP pin. The RC pin has a sawtooth type waveform and the COMP signal should have a steady voltage, inversely proportional to the required frequency.

Both the maximum and minimum voltage on the COMP pin (and therefore maximum and minimum frequencies) are set by the limit block. The COMP pin voltage can vary from 0.5V ($V_{COMPMIN}$) to 2.3V ($V_{COMPMAX}$), resulting in a maximum to minimum frequency ratio of approximately 5 for any specific DC bulk voltage.

The timing capacitor C_{RC} may be chosen within the range 100 – 470 pF. The recommended value is 330pF.

The oscillator timing resistor R_{RC} may be connected to either V_{DD} or to the rectified DC bus, V_{HT} . If connected to V_{DD} , the value of R_{RC} may be calculated using following equation.

$$F_{MIN} = \frac{1}{2 \left(0.8\mu s + R_{RC} \cdot C_{RC} \cdot \ln \left(1 - \frac{2.3}{3.4} \right) \right)}$$

This equation gives the lowest possible operating frequency of the converter.

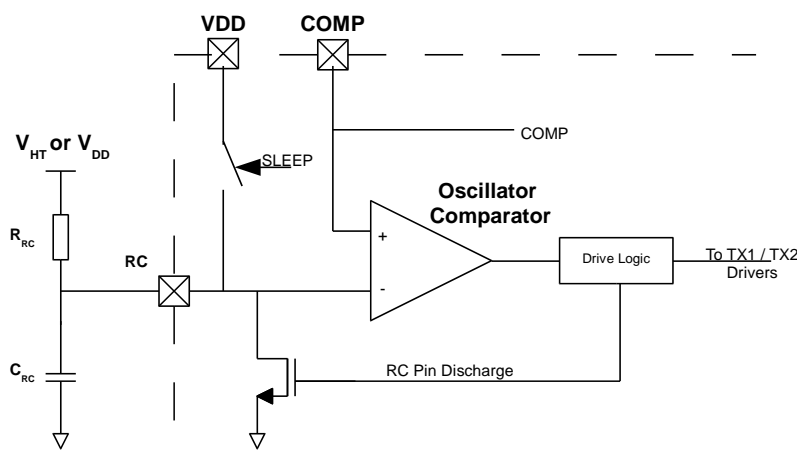

Figure 8: Oscillator circuit

Feedforward Compensation

The oscillator may optionally include feedforward compensation. Feedforward compensation is recommended to minimise the line frequency voltage ripple on the output, particularly for off-line applications where the DC bulk supply is unregulated. To apply the feedforward compensation, the oscillator pull-up resistor R_{RC} is connected to the DC bulk supply, V_{HT} instead of V_{DD} (see Figure 3). The value may be

calculated as a function of the DC bulk voltage using the following equation:

$$F_{MIN} = \frac{1}{2(0.8\mu s + R_{RC} \cdot C_{RC} \cdot 2.3/V_{HT})}$$

To assist feedforward applications, a switch is provided which connects the VDD pin to the RC pin while the controller is in SLEEP. This allows the R_{RC} resistor to pull up the VDD supply for start up.

Standby

The IC enters a controlled burst-mode operation at light load, by switching in and out of STANDBY, thereby minimising the converter's input power consumption.

Standby Entry

RED1501 can enter standby when either the IC reaches its maximum allowable operating frequency; or when a low load condition is detected. The circuit that forces the IC into standby is shown in Figure 9.

When the output load current is low, so is the average primary current. This current is monitored by a comparator that senses when the current has fallen below a desired threshold. In a typical application this is the main reason for the IC entering standby. So, the result is when the output current falls, the RED1501 goes into STANDBY and the overall application standby power is reduced.

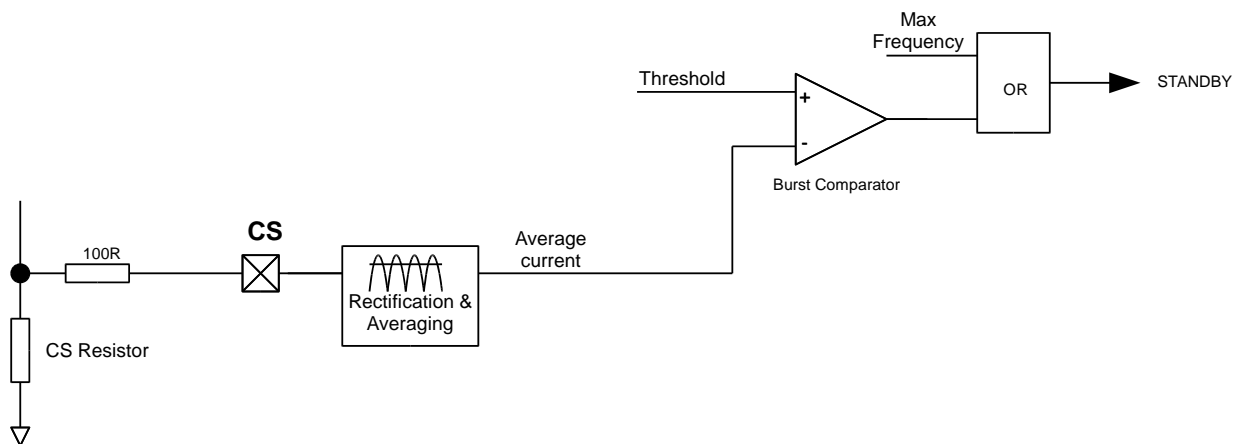

Figure 9: STANDBY entry circuit

Standby Exit

When the IC enters STANDBY, load is normally low and RED1501 is operating at a high frequency. This means that COMP is usually at the lower end of its operating range. During standby, the output voltage should fall and the control loop will request more power from the LLC converter.

When the IC senses that the control loop requires more power, the controller will exit out of standby and begin the start sequence. The converter will again deliver power to the load and the IC will remain out of standby for a while until the load falls again, when the IC re-enters standby.



Feedback Protection

The RED1501 includes a feedback protection feature that stops the converter if the feedback signal is lost. In any switching cycle, if the converter runs at minimum frequency, the overload counter counts up. (Normally, the overload counter counts down to zero). If the overload count reaches 8192, the IC goes into SLEEP mode and the converter shuts down, with both TX pins in the clamping state, preventing converter oscillation.

After 32 dummy restart attempts, (typically 2s) the converter will re-start again. The IC issues start pulses and the converter starts up as normal. If the overload persists, the converter will shut down again, but if the overload has been removed, the converter will continue operating normally.

ABSOLUTE MAXIMUM RATINGS

CAUTION: Permanent damage may result if a device is subjected to operating conditions at or in excess of absolute maximum ratings.

Parameter	Symbol	Condition	Min	Max	Unit
Supply voltage	V _{DD}		-0.5	4.5	V
Supply current	I _{DD}		0	10	mA
Input/output voltages	V _{IO}		-0.5	V _{DD} + 0.5	V
Input/output currents	I _{IO}		-10	10	mA
Junction temperature	T _J		-20	+125	°C
Storage temperature	T _P		-20	+125	°C
Lead temperature	T _L	Soldering, 10 s		260	°C
ESD withstand		Human body model, JESD22-A114		2	kV
		Capacitive Discharge Model		500	V

NORMAL OPERATING CONDITIONS

Unless otherwise stated, electrical characteristics are defined over the range of normal operating conditions. Functionality and performance is not defined when a device is subjected to conditions outside this range and device reliability may be compromised.

Parameter	Symbol	Condition	Min	Typ	Max	Unit
Minimum supply current	I _{DDMIN}	IC Shunt Regulator off	0.5		1.0	mA
Full-Power (minimum) switching frequency	F _{MIN}	C _{RC} =330p; R _{RC} = 33k (to V _{DD})		38		kHz
Junction temperature	T _J		0	25	125	°C

ELECTRICAL CHARACTERISTICS

Unless otherwise stated:

- Min and Max electrical characteristics apply over normal operating conditions.
- Typical electrical characteristics apply at T_J = T_{J(TYP)} and I_{DD} = I_{DDREG(TYP)}.
- The chip is operating in RUN mode.
- Voltages are specified relative to the GND pin.

VDD Pin

Parameter	Symbol	Condition	Min	Typ	Max	Unit
Supply voltage	V _{DDSTART}	To enter RUN mode	3.2	3.6	4.0	V
	V _{DDREG}	I _{DD} < I _{DDSHUNT}	3.2	3.4	3.6	V
	ΔV _{DDSA}	To trigger STAYALIVE signal	0.4	0.5	0.6	V
	ΔV _{DDSLLEEP}	To enter SLEEP mode	0.9	1.0	1.1	V
Supply current	I _{DDREG}	In RUN mode, V _{DD} < V _{DDREG}		0.7	1	mA
	I _{DDSLLEEP}	In SLEEP mode		8	15	μA
	I _{DDSHUNT}	V _{DD} shunt regulator limit	4	6	8	mA



RED1501 LLC Controller IC

VFB Pin

Parameter	Symbol	Condition	Min	Typ	Max	Unit
VFB threshold voltage	V _{REF}		1.14	1.19	1.24	V

CS Pin

Parameter	Symbol	Condition	Min	Typ	Max	Unit
Overload protection threshold voltage	V _{OVLTHR}	V _{COMP} =1.8V – 120% load		125		mV
Constant current limit	V _{CCLIM}	140% load		150		mV
Instantaneous over-current protection threshold	V _{OCPTHR}			400		mV

RC Pin

Parameter	Symbol	Condition	Min	Typ	Max	Unit
External capacitor range	C _{RC}		100	330	470	pF
Oscillator Frequency Variation	ΔF _{RC} /F _{RC}	T _J = -0°C to 105°C, C _{RC} =330pF, V _{DD} =3.4V, V _{COMP} = V _{COMPMAX}			4	%
Oscillator reset time	T _{RCRST}			0.8		μs
Overload trigger cycle count	N _{OVLTR}	V _{CSAVG} > V _{OVLTHR}		8192		Cycles
Overload recovery cycle count	N _{OVLRS}			32		Cycles

COMP Pin

Parameter	Symbol	Condition	Min	Typ	Max	Unit
Source/Sink current	I _{COMP}		-40		+40	μA
Maximum COMP voltage	V _{COMPMAX}			2.3		V
Minimum COMP voltage	V _{COMPMIN}			0.5		V

TX1, TX2 Pins

Parameter	Symbol	Condition	Min	Typ	Max	Unit
On-state resistance	R _{TXON}			1.5	2	Ω
TX pin clamp current	I _{TXCLAMP}	TX pin frequency >20kHz			500	mA
Start-pulse output current	I _{TXSTART}		6	8	10	mA
Start-pulse width	T _{TXSTART}		300	500	700	ns

Over-Temperature Protection (OTP)*

Parameter	Symbol	Condition	Min	Typ	Max	Unit
Over-Temperature trip threshold	T _{OTPS}		123	125	128	°C
Over-Temperature reset threshold	T _{OTPR}		98	100	103	°C

*: not tested in production

PACKAGE INFORMATION

Package Dimensions

SO8 package dimensions are shown below. All units are in mm.

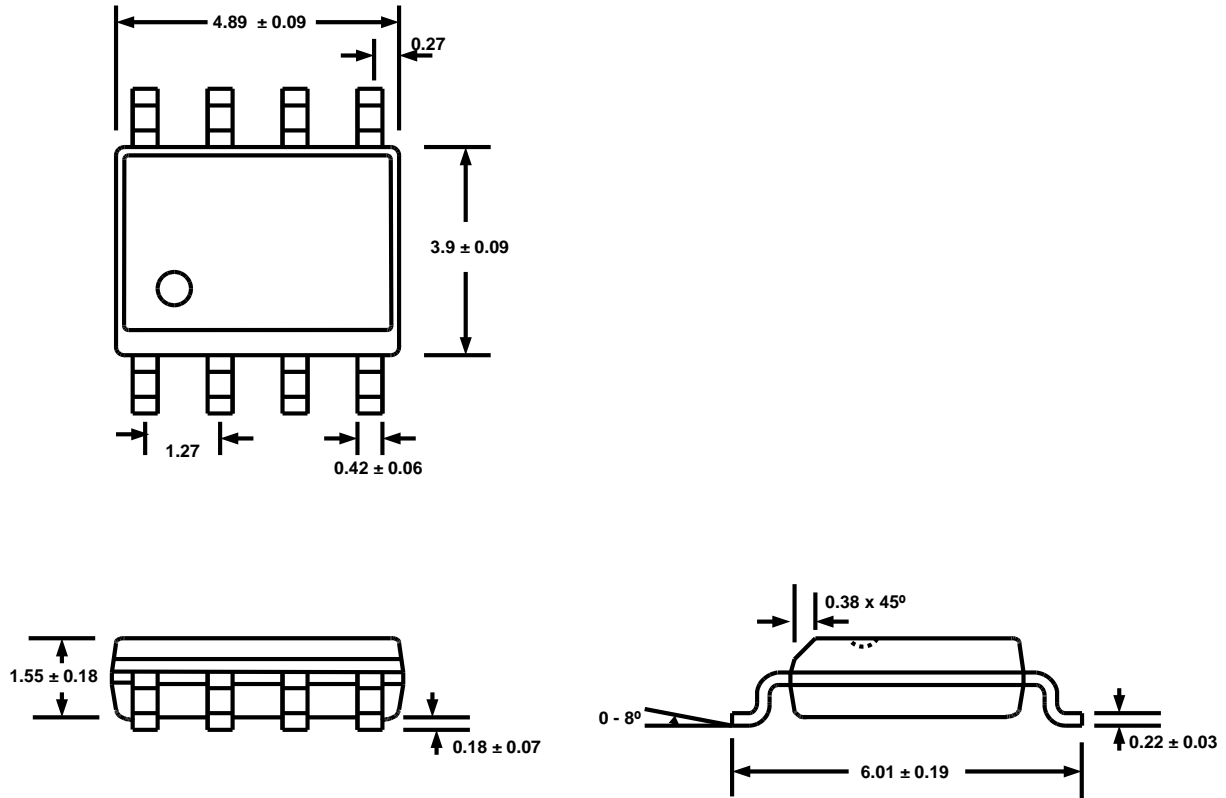

Available packages

Package type	Part number	Moisture Sensitivity Level (MSL)	Packaging
SO8	RED1501AD-TR13	3 (JEDEC J-STD-020)	Tape and reel 2500 / 13" reel

Package Marking

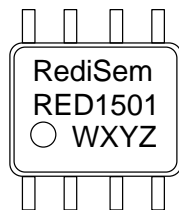

SO8 top-side marking for RED1501

RED1501= Part Number

WXYZ= Lot Code, e.g. AAAA, AAAB



Status

The status of this Datasheet is shown in the footer.

Datasheet Status	Product Status	Definition
Preview	In development	The Datasheet contains target specifications relating to design and development of the described IC product.
Preliminary	In qualification	The Datasheet contains preliminary specifications relating to functionality and performance of the described IC product.
Production	In production	The Datasheet contains specifications relating to functionality and performance of the described IC product which are supported by testing during development and production.

Contact Details

RediSem Ltd.

218-219 Photonics Centre
No 2 Science Park East Avenue
Hong Kong Science & Technology Park
Shatin, New Territories
Hong Kong

Tel. +852 2607 4141
Fax. +852 2607 4140
Email: info@redisem.com
Web: www.redisem.com

Disclaimer

The product information provided herein is believed to be accurate and is provided on an “as is” basis. RediSem Ltd assumes no responsibility or liability for the direct or indirect consequences of use of the information in respect of any infringement of patents or other rights of third parties. RediSem Ltd does not grant any licence under its patent or intellectual property rights or the rights of other parties. Any application circuits described herein are for illustrative purposes only. Specifications are subject to change without notice. In respect of any application of the product described herein RediSem Ltd expressly disclaims all warranties of any kind, whether express or implied, including, but not limited to, the implied warranties of merchantability, fitness for a particular purpose and non-infringement of third party rights. No advice or information, whether oral or written, obtained from RediSem Ltd shall create any warranty of any kind. RediSem Ltd shall not be liable for any direct, indirect, incidental, special, consequential or exemplary damages, howsoever caused including but not limited to, damages for loss of profits, goodwill, use, data or other intangible losses.

The products and circuits described herein are subject to the usage conditions and end application exclusions as outlined in RediSem Ltd Terms and Conditions of Sale.

RediSem Ltd reserves the right to change specifications without notice. To obtain the most current product information available visit www.redisem.com or contact us at the address shown above.