

## Improved Resonant Controller for CV LED Drivers

### Features

- Reduced pincount for smaller size & lower cost
- Reduced audio noise with improved burst-mode performance
- Reduced output ripple
- Improved transient response
- Reduced standby power
- Accurate primary side limiting of output current
- Boost current feature to ensure reliable startup with constant power loads
- Protection modes:
  - Overload output including short-circuit
  - No-Load output
  - Over-temperature
- Low standby power
- Smallest SOT23-6 IC package



SOT23-6

### Applications

- Passive PFC CV LED drivers 80W
- Active PFC CV LED drivers up to 200W

### Order code

| Part Number   | Package | Packaging     |
|---------------|---------|---------------|
| RED2543AL-TR7 | SOT23-6 | Tape and reel |

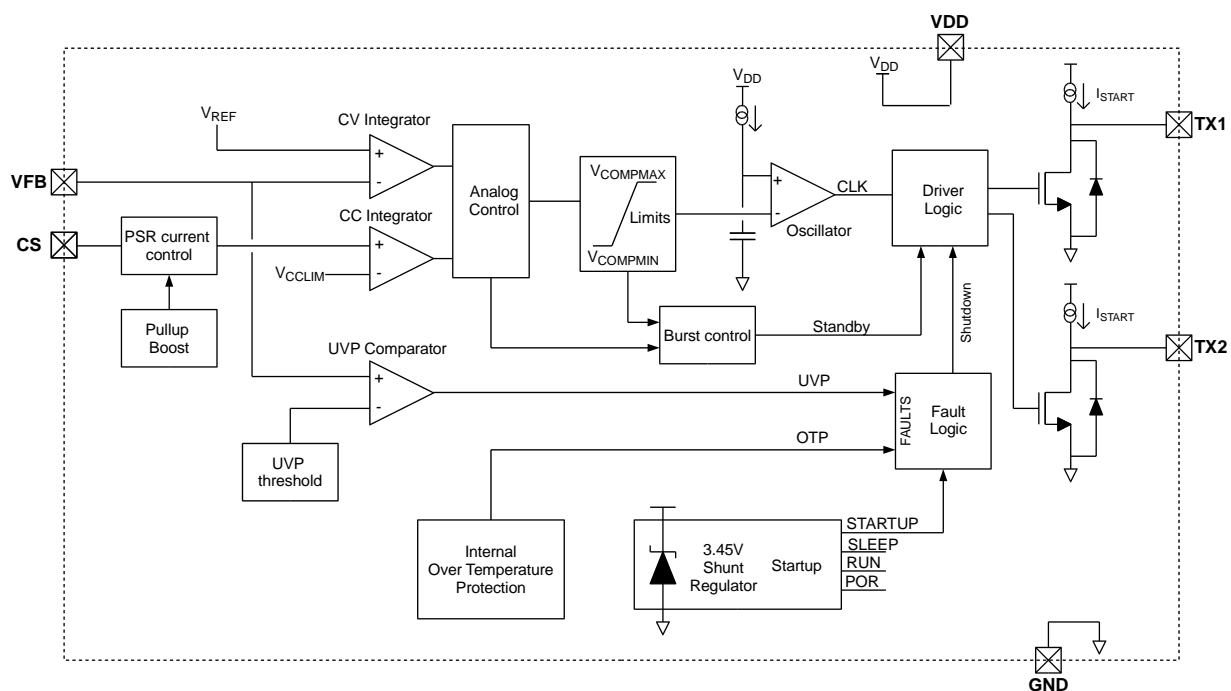

Figure 1: Block diagram

## Device Pins

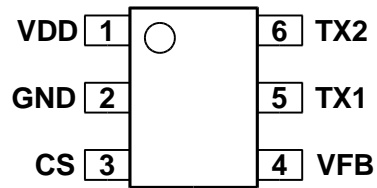

Figure 2: SOT23-6 pin connections (top view)

## Pin Functions

| Pin # | Name | Function                                                                                                                                                                 |
|-------|------|--------------------------------------------------------------------------------------------------------------------------------------------------------------------------|
| 1     | VDD  | IC Power Supply pin                                                                                                                                                      |
| 2     | GND  | Chip ground                                                                                                                                                              |
| 3     | CS   | PSR Current Sense input provides output current regulation and cycle-by-cycle over-current protection. The CS pin is connected to the half-bridge current sense resistor |
| 4     | VFB  | PSR Feedback input for output voltage regulation. Connect to primary sense winding                                                                                       |
| 5     | TX1  | Output to control transformer                                                                                                                                            |
| 6     | TX2  | Output to control transformer                                                                                                                                            |

## Typical Application

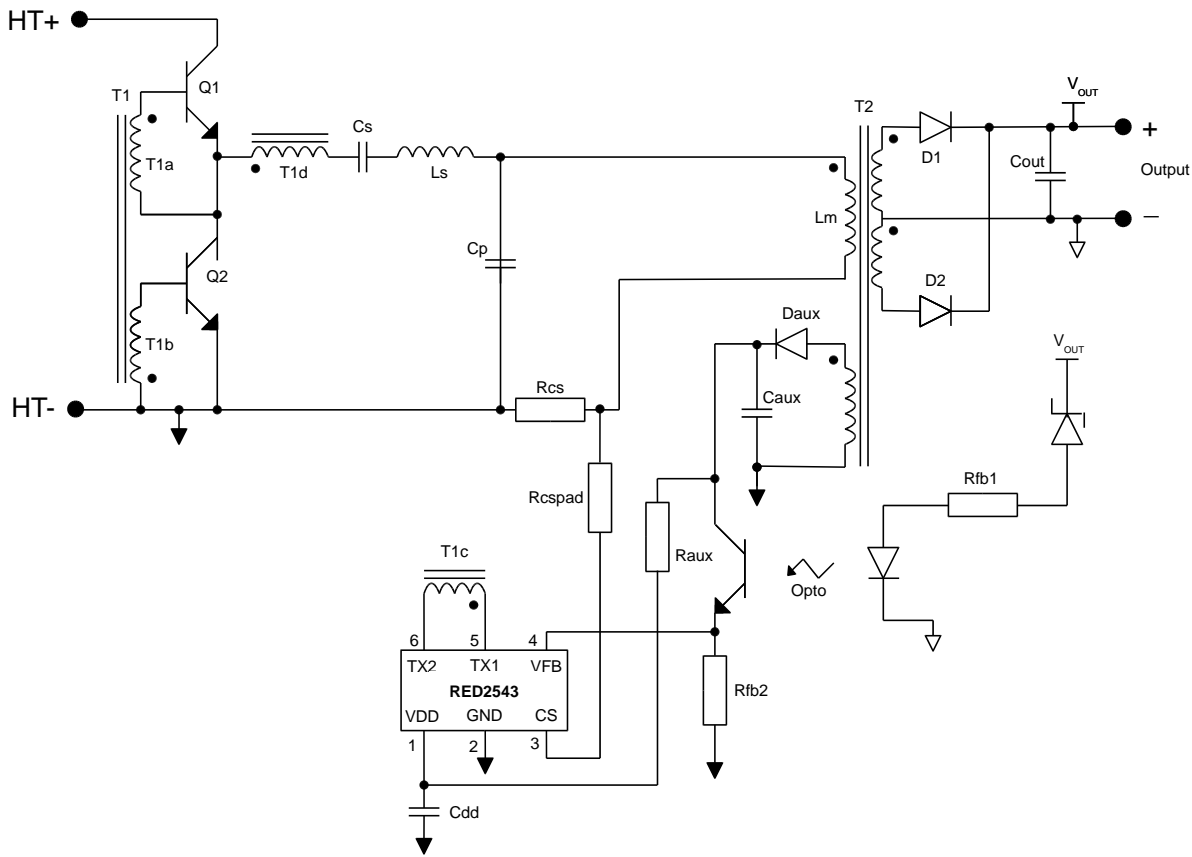

Figure 3: Typical Application Schematic: LLC converter with RED2543 CV controller

## Features

RED2543 is an advanced CMOS control IC for resonant converters such as LC, LLC and LCC. The RED2543 control scheme accurately controls the driver output voltage by means of secondary side feedback employing an amplifier and optocoupler. The IC also accurately controls the driver output current with RediSem's PSR technique, reducing cost, complexity and power consumption.

RED2543 uses the CSOC (Controlled Self-Oscillating Converter) scheme to drive two low-cost bipolar transistors in a half-bridge configuration. RED2543 is optimized to work with RediSem's resonant converter topology that can include integrated Power Factor Correction.

The RED2543 PSR scheme regulates the LED drive current by modulating the converter frequency. Primary side current control enables very accurate overload regulation and detection.

The IC enters a controlled burst-mode operation at light load, minimising the converter's input power consumption. The point at which the IC enters burst mode is pre-set to a value derived from the primary-side current to keep the output voltage

from rising and to keep the power consumption low.

### Protection Features

The IC is able to detect a number of faults that cause the IC to enter a fault mode:

- Output overload
- Output short circuit
- Over-temperature fault

During these fault conditions, the IC will continually attempt to re-start. Depending on the fault, there can be 8 dummy re-starts between re-start attempts when the IC re-starts while the converter remains off.

If the output is short-circuit, the auxiliary power to the IC fails and the IC shuts down. The IC detects this and when it next re-starts, it does so at half output current. It continues to do so until the short has been removed. If the fault is removed, the IC will automatically return to full output current.

The IC also has an instantaneous cycle-by-cycle over-current protection (OCP) level that will



## RED2543 LED LLC Controller

---

terminate any cycle instantaneously should the current exceed a pre-set level.

### ***Over-temperature Protection & Shutdown***

An internal over-temperature protection shuts down the controller if the IC temperature exceeds 125°C. The IC will restart the converter when the IC temperature drops by 8°C.

### ***Automatic Dead-Time Control***

An important feature of the Controlled Self Oscillating Converter is that the dead-time is controlled naturally. Unlike MOSFET half-bridge converters, it is not necessary to program the

dead-time on RED2543. The bipolar switching transistors are turned on correctly through the self-oscillation of the converter and turned off by RED2543. This greatly simplifies the design process and improves the robustness of the LLC converter.

### ***Capacitive Mode Protection***

RED2543 includes a capacitive mode protection feature which prevents the converter from entering capacitive switching mode on a cycle-by-cycle basis by limiting the minimum frequency. This always ensures the Controlled Self Oscillating Converter continues to oscillate correctly.

## IC Operation

### Startup, Shutdown and re-start

Figure 4 shows typical startup waveforms for RED2543. In SLEEP mode the  $I_{DD}$  current is approximately  $8\mu A$  ( $I_{DD\text{SLEEP}}$ ). Once VDD reaches  $3.7V$  ( $V_{DD\text{START}}$ ) the IC enters STARTUP mode. During the initial period of approximately  $40ms$  ( $2048$  cycles) VDD is allowed to drop to  $2.4V$  or rise to  $3.6V$ . This gives time for the application to pull up the output voltage. After this the IC enters

RUN mode when the controlled Zener clamp inside the IC regulates the VDD voltage to  $3.45V$  ( $V_{DD\text{REG}}$ ). The IC current is now approximately  $400\mu A$  ( $I_{DD\text{REG}}$ ) plus any excess current required to clamp VDD to  $3.45V$ . If VDD falls below  $3.45V$  ( $V_{DD\text{REG}}$ ) the Zener clamp turns off and  $I_{DD}$  reduces to  $400\mu A$  ( $I_{DD\text{REG}}$ ) only. If VDD falls below  $2.9V$  ( $V_{DD\text{SLEEP}}$ ), the IC enters SLEEP mode. In this condition  $I_{DD}$  reduces to  $8\mu A$ . ( $I_{DD\text{SLEEP}}$ ).

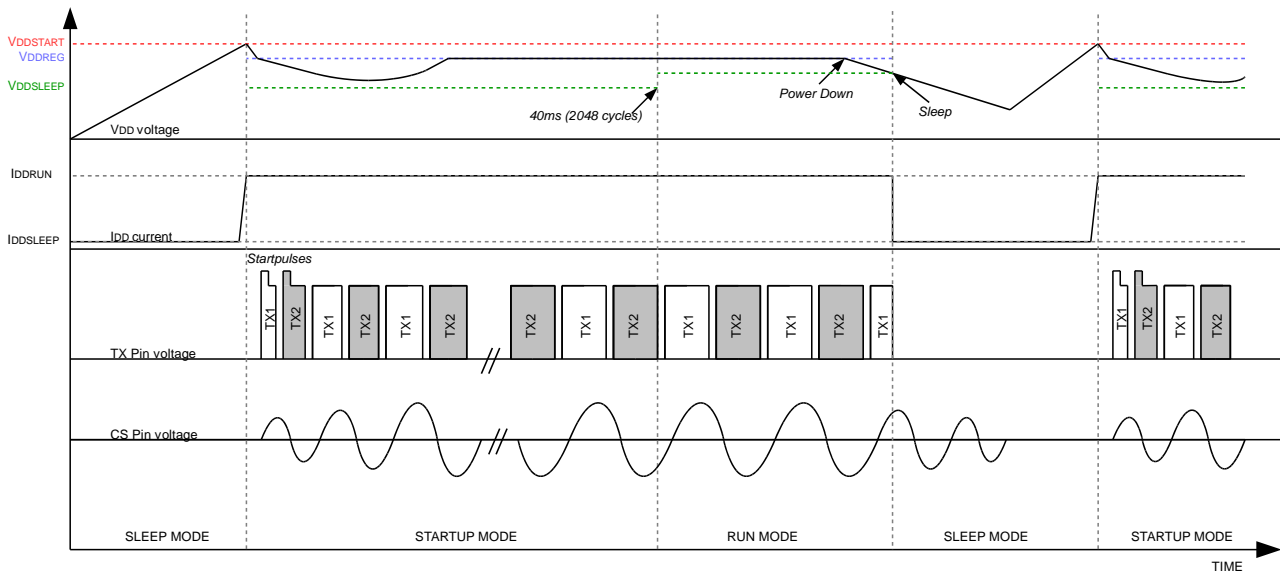

Figure 4: IC Start-up waveforms

### Output stage

A diagram of the output stage can be seen in Figure 5. To start the converter oscillating the RED2543 issues start pulses through the TX pins during the first two cycles. These start pulses are  $800ns$  long ( $t_{TX\text{START}}$ ) and provide current pulses ( $I_{TX\text{START}}$ ) from both TX1 and TX2 pins. After this the converter self-oscillates and no longer needs

start pulses to maintain oscillation. A low on-state NMOS transistor is used to turn the bipolar transistors off. It is controlled by the oscillator off-time. The NMOS device is turned to pull TX pin low, which switches off the corresponding bipolar transistor in the power converter half-bridge.

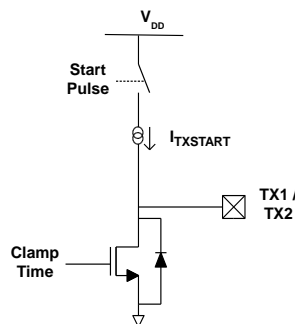

Figure 5: Output Stage

## Voltage and current Regulation

The converter's output voltage and current are controlled by two independent amplifiers within the IC, as shown in figure 1. Inside the IC there are two separate control loops that control the converter output voltage (in normal operation) and

output current (during pullup or overload). The RED2543 regulates the output current and voltage by controlling the frequency. An Oscillator Control Voltage is fed into the oscillator comparator to give the desired operating frequency.

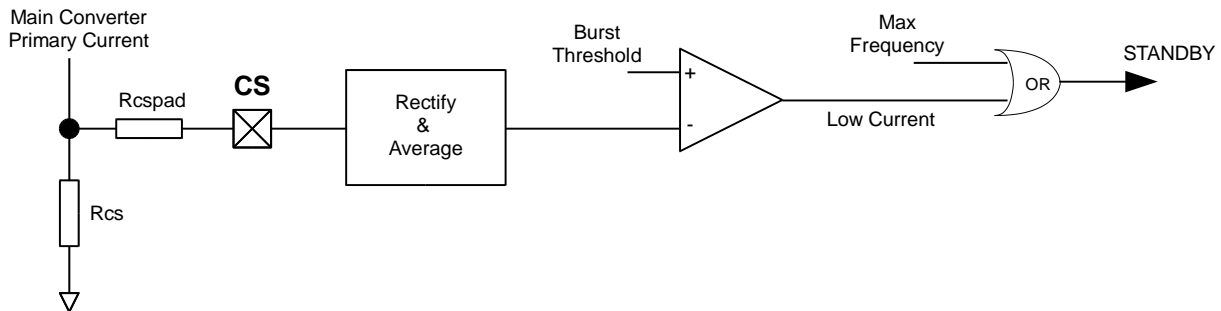

Figure 6: Standby Entry Circuit

## Voltage Control

The VFB pin of the RED2543 is internally connected to a high gain amplifier. The voltage on the VFB pin is compared to the reference voltage of 1.2V and the error is compensated for and an oscillator control voltage is generated. This control voltage has upper and lower limits that restricts the upper and lower frequency of the converter. The voltage loop has a compensated high gain to maximise transient response and minimise ripple whilst being stable throughout the load and line variations. A simple external control loop using a secondary side reference (e.g. TL431) and an optocoupler is typically used to complete the control loop.

## Light loads

The IC has a burst mode that is used to lower the input power at light loads so that standby power is minimised. The standby point is internally set to 5% of rated load current. Below this point, the IC enters a controlled burst-mode operation at light load, by switching in and out of STANDBY, thereby

minimising the converter's input power consumption.

## Standby Entry

RED2543 will enter standby when either the IC reaches its maximum allowable operating frequency; or when a low load condition is detected. When the IC detects this condition, it goes into standby. This can be seen in figure 6. In standby mode, the converter is held in the off condition, with the IC waiting for a standby exit signal

## Standby Exit

During standby, the output voltage will fall slightly. The control loop then demands more power by turning the optocoupler off slightly, thereby lowering the voltage on the VFB pin. When the IC senses this, the controller will exit out of standby and begin the start sequence. The converter will again deliver power to the load and the IC will remain out of standby for a while until the load falls again, when the IC re-enters standby.

## **PSR Current Control**

Current regulation is used during pullup and during overload conditions. There are two current control methods used in the converter:

1. constant current (CC) regulation.
2. an instantaneous peak current limit (OCP).

## **PSR Average current estimation**

The signal from the CS pin is divided into two different paths. The bottom path provides peak instantaneous over-current protection (OCP) while the PSR Average Current estimation block provides the current regulation (CC) information. The voltage on the CS pin is an AC signal biased around GND. Inside the PSR block this signal is processed to provide a voltage proportional to the average converter output current.

## **Starting pullup capacity**

The RED2543 includes an increased ability to pull up capacitive and constant power loads by temporarily increasing the constant-current level. By increasing the size of the CSpad resistor the converter will be able to deliver higher loads at startup. There is a minimum of 20% additional pullup with a zero-ohm CSpad resistor, and a 120% increase with a 200R CSpad resistor. With increased pullup capacity, take care to check the series resonant inductor flux density and current & voltage rating of components during startup.

## **Constant Current Regulation**

CC operation is defined by an internally compensated control loop. The average current regulation point,  $V_{CCREG}$  is pre-set to 165mV, referred to the CS pin.

## **Oscillator**

The RED2543 includes an internal oscillator which is used to control the switching frequency of the converter. The maximum and minimum frequency limits are pre-set inside the IC and have been chosen to suit a low power CSOC converter. The oscillator ramp is compared to an internal control voltage to produce the correct frequency required to regulate the converter.

## **Over Current Protection**

Over-Current Protection (OCP) is an instantaneous termination of the current oscillator cycle and the transistor on-time. When a peak voltage greater than 450mV ( $V_{OCPTH}$ ) is sensed on the CS pin the OCP comparator terminates the current oscillator on-time cycle. The oscillator is reset and the off-time begins resulting in the bipolar transistors turning off and the half-bridge commutating. This is repeated in subsequent cycles whenever the CS voltage exceeds the threshold. However, in a correctly designed converter it should not be possible to trip OCP in normal operation.

## ABSOLUTE MAXIMUM RATINGS

CAUTION: Permanent damage may result if a device is subjected to operating conditions at or in excess of absolute maximum ratings.

| Parameter             | Symbol          | Condition                                                       | Min  | Max                   | Unit |
|-----------------------|-----------------|-----------------------------------------------------------------|------|-----------------------|------|
| Supply voltage        | V <sub>DD</sub> | SLEEP mode: self-limited by IC start-up (V <sub>DDSTART</sub> ) | -0.5 | 4.5                   | V    |
| Supply voltage        | V <sub>DD</sub> | RUN mode: Self-limited by internal shunt regulator              | -0.5 | 4.0                   | V    |
| Supply current        | I <sub>DD</sub> |                                                                 | 0    | 2                     | mA   |
| Input/output voltages | V <sub>IO</sub> |                                                                 | -0.5 | V <sub>DD</sub> + 0.5 | V    |
| Input/output currents | I <sub>IO</sub> |                                                                 | -10  | 10                    | mA   |
| Junction temperature  | T <sub>J</sub>  | T <sub>J,MAX</sub> limited by OTP (T <sub>OTPS_MAX</sub> )      | -20  | +135                  | °C   |
| Storage temperature   | T <sub>P</sub>  |                                                                 | -20  | +125                  | °C   |
| Lead temperature      | T <sub>L</sub>  | Soldering, 10 s                                                 |      | 260                   | °C   |
| ESD withstand         |                 | Human body model, JESD22-A114                                   |      | 2                     | kV   |
|                       |                 | Capacitive Discharge Model                                      |      | 500                   | V    |

## NORMAL OPERATING CONDITIONS

Unless otherwise stated, electrical characteristics are defined over the range of normal operating conditions. Functionality and performance are not defined when a device is subjected to conditions outside this range and device reliability may be compromised.

| Parameter              | Symbol             | Condition | Min | Typ | Max | Unit |
|------------------------|--------------------|-----------|-----|-----|-----|------|
| Minimum supply current | I <sub>DDMIN</sub> |           | 350 | 400 | 450 | uA   |
| Junction temperature   | T <sub>J</sub>     |           | -20 | 25  | 125 | °C   |

## ELECTRICAL CHARACTERISTICS

Unless otherwise stated:

- Min and Max electrical characteristics apply over normal operating conditions.
- Typical electrical characteristics apply at T<sub>J</sub> = T<sub>J(TYP)</sub> and I<sub>DD</sub> = I<sub>DDREG(TYP)</sub>.
- The chip is operating in RUN mode.
- Voltages are specified relative to the GND pin.

### VDD Pin

| Parameter      | Symbol               | Condition                                         | Min  | Typ  | Max  | Unit |
|----------------|----------------------|---------------------------------------------------|------|------|------|------|
| Supply voltage | V <sub>DDSTART</sub> | Enter RUN mode from SLEEP                         | 3.2  | 3.7  | 4.2  | V    |
|                | V <sub>DDREG</sub>   | I <sub>DD</sub> < I <sub>DDSHUNT</sub>            | 3.25 | 3.45 | 3.65 | V    |
|                | V <sub>DDSLEEP</sub> | To enter SLEEP mode                               | 2.7  | 2.9  | 3.1  | V    |
| Supply current | I <sub>DDREG</sub>   | In RUN mode, V <sub>DD</sub> < V <sub>DDREG</sub> | 350  | 400  | 450  | μA   |
|                | I <sub>DDSLEEP</sub> | In SLEEP mode                                     |      | 8    | 30   | μA   |
|                | I <sub>DDSHUNT</sub> | V <sub>DD</sub> shunt regulator max current       |      |      | 2    | mA   |





# RED2543 LED LLC Controller

## VFB Pin

| Parameter             | Symbol           | Condition                                            | Min  | Typ  | Max  | Unit |
|-----------------------|------------------|------------------------------------------------------|------|------|------|------|
| VFB threshold voltage | V <sub>REF</sub> | T <sub>J</sub> = 0°C to 85°C, V <sub>DD</sub> =3.45V | 1.15 | 1.20 | 1.25 | V    |

## CS Pin

| Parameter                                       | Symbol             | Condition                                  | Min | Typ | Max | Unit |
|-------------------------------------------------|--------------------|--------------------------------------------|-----|-----|-----|------|
| Constant current regulation                     | V <sub>CCREG</sub> | DC CS signal. T <sub>J</sub> = 0°C to 85°C | 162 | 165 | 168 | mV   |
| Instantaneous over-current protection threshold | V <sub>OCPTH</sub> |                                            |     | 450 |     | mV   |
| Internal Rcspad                                 | R <sub>CSPAD</sub> |                                            |     | 200 |     | Ω    |

## Oscillator

| Parameter                          | Symbol | Condition | Min | Typ | Max  | Unit |
|------------------------------------|--------|-----------|-----|-----|------|------|
| Nominal oscillator frequency range |        |           | <33 |     | >170 | kHz  |

## TX1, TX2 Pins

| Parameter                  | Symbol                 | Condition               | Min | Typ | Max | Unit |
|----------------------------|------------------------|-------------------------|-----|-----|-----|------|
| On-state resistance        | R <sub>TXON</sub>      |                         |     | 1   | 1.5 | Ω    |
| TX pin clamp current       | I <sub>TXCLAMP</sub> * | TX pin frequency >30kHz |     |     | 800 | mA   |
| Start-pulse output current | I <sub>TXSTART</sub>   | TX pin voltage 2V       |     | 17  |     | mA   |
| Start-pulse width          | T <sub>TXSTART</sub>   |                         |     | 800 |     | ns   |

## Over-Temperature Protection (OTP)\*

| Parameter                                    | Symbol               | Condition           | Min | Typ | Max | Unit |
|----------------------------------------------|----------------------|---------------------|-----|-----|-----|------|
| Over-Temperature Protection threshold        | T <sub>OTPS</sub>    | At silicon junction | 115 | 125 | 135 | °C   |
| Over-Temperature Protection reset hysteresis | T <sub>OTP_HYS</sub> | At silicon junction |     | 8   |     | °C   |

\*: not tested in production

## PACKAGE INFORMATION

### Package Dimensions

SOT23-6 package dimensions are shown below. All units are in mm.

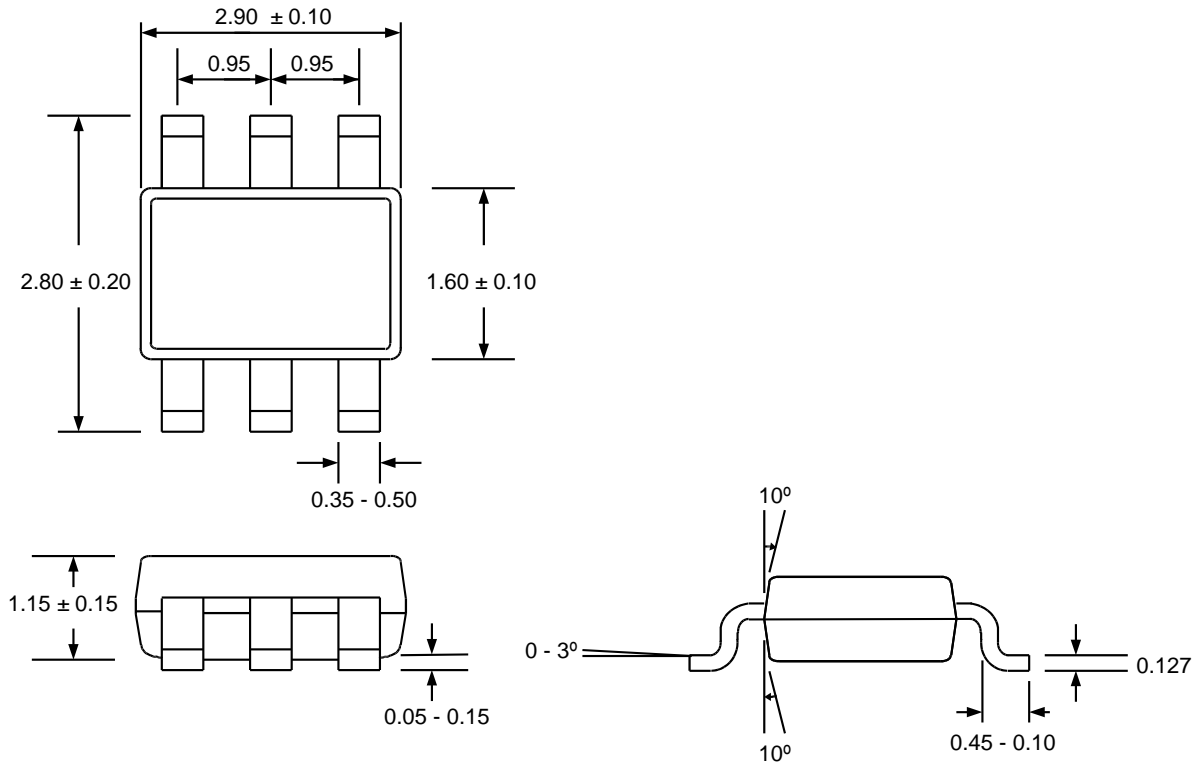

### Available packages

| Package type | Part number   | Moisture Sensitivity Level (MSL) | Packaging                       |
|--------------|---------------|----------------------------------|---------------------------------|
| SOT23-6      | RED2543AL-TR7 | 3 (JEDEC J-STD-020)              | Tape and reel<br>3000 / 7" reel |

### Package Marking

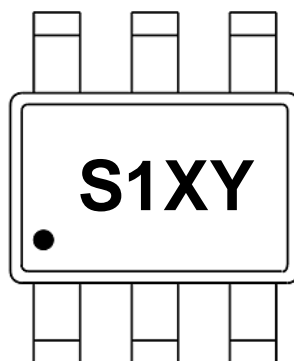

#### SOT23-6 top side marking for RED2543

S1XY:  
S1 = RED2543  
XY = Lot Code starting with AA, then AB, AC etc.



## Status

The status of this Datasheet is shown in the footer.

| Datasheet Status | Product Status   | Definition                                                                                                                                                                    |
|------------------|------------------|-------------------------------------------------------------------------------------------------------------------------------------------------------------------------------|
| Preview          | In development   | The Datasheet contains target specifications relating to design and development of the described IC product.                                                                  |
| Preliminary      | In qualification | The Datasheet contains preliminary specifications relating to functionality and performance of the described IC product.                                                      |
| Production       | In production    | The Datasheet contains specifications relating to functionality and performance of the described IC product which are supported by testing during development and production. |

## Contact Details

**RediSem Ltd.**  
218-219 Photonics Centre  
No 2 Science Park East Avenue  
Hong Kong Science Park  
Shatin, New Territories  
Hong Kong

Tel. +852 2607 4141  
Fax. +852 2607 4140  
Email: [info@redisem.com](mailto:info@redisem.com)  
Web: [www.redisem.com](http://www.redisem.com)

## Disclaimer

The product information provided herein is believed to be accurate and is provided on an “as is” basis. RediSem Ltd assumes no responsibility or liability for the direct or indirect consequences of use of the information in respect of any infringement of patents or other rights of third parties. RediSem Ltd does not grant any licence under its patent or intellectual property rights or the rights of other parties.

Any application circuits described herein are for illustrative purposes only. Specifications are subject to change without notice. In respect of any application of the product described herein RediSem Ltd expressly disclaims all warranties of any kind, whether express or implied, including, but not limited to, the implied warranties of merchantability, fitness for a particular purpose and non-infringement of third party rights. No advice or information, whether oral or written, obtained from RediSem Ltd shall create any warranty of any kind. RediSem Ltd shall not be liable for any direct, indirect, incidental, special, consequential or exemplary damages, howsoever caused including but not limited to, damages for loss of profits, goodwill, use, data or other intangible losses.

The products and circuits described herein are subject to the usage conditions and end application exclusions as outlined in RediSem Ltd Terms and Conditions of Sale.

RediSem Ltd reserves the right to change specifications without notice. To obtain the most current product information available visit [www.redisem.com](http://www.redisem.com) or contact us at the address shown above.